

HYBRID-HIGH RELIABILITY RADIATION TOLERANT DC-DC CONVERTER

+28V Input, Single/Dual Output

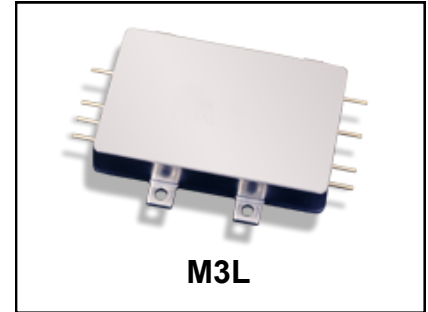

Description

The M3L-Series of DC-DC converters are radiation tolerant, high reliability devices designed for moderate radiation environments such as those encountered by low earth orbit satellites and launch vehicles. For higher radiation environments, the M3G-Series of DC-DC converters is recommended. Features include small size, low weight and a high tolerance to total ionizing dose, single event effects and environmental stresses such as temperature extremes, mechanical shock, and vibration. All components are fully de-rated to meet the requirements of MIL-STD-975 and MIL-STD-1547 and GSFC PPL-21 Appendix B. Extensive documentation including Radiation Susceptibility, Thermal Analysis, Stress Analysis and MTBF are available.

The converters incorporate a fixed frequency single forward topology with magnetic feedback and an internal EMI filter. These converters are capable of meeting the conducted emissions and conducted susceptibility requirements of MIL-STD-461C without any additional components. All models include an external inhibit port and have an adjustable output voltage. They are enclosed in a hermetic 1.5" x 2.3" x 0.425" steel package and weigh less than 85 grams. The package utilizes rugged ceramic feed-through copper core pins and is sealed using parallel seam welding.

Manufactured in a facility fully qualified to MIL-PRF-38534, these converters are fabricated utilizing DLA Land and Maritime qualified processes. For available screening options, refer to device screening table in the data sheet.

Non-flight versions of the M3L-Series converters are available for system development purposes. Variations in electrical specifications and screening to meet custom requirements can be accommodated. Consult IR HiRel San Jose for special requirements.

Features

- Total Dose > 25 kRads(Si)
- SEE Hardened to LET up to 37 MeV.cm²/mg
- Internal EMI filter; Converter Capable of meeting MIL-STD-461C CE03 and CS01
- Low Weight < 85 grams
- Magnetically Coupled Feedback
- 16V to 50V Input Range
- Up to 25W Output Power
- Single and Dual Output Models Include 3.3, 5, 12, 15, ±5, ±12, ±15V
- High Efficiency - to 82%
- -55°C to +125°C Operating Temperature Range
- 100MΩ @ 500VDC Isolation
- Under-Voltage Lockout
- Short Circuit and Overload Protection
- Adjustable Output Voltage
- External Inhibit
- 1,500,000 Hour MTBF

Applications

- Low Earth Orbit Satellites (LEO)
- Launch Vehicles

Circuit Description

The M3L-Series converters utilize a single-ended forward topology with resonant reset. The nominal switching frequency is 500 kHz. Electrical isolation and tight output regulation are achieved through the use of a magnetically coupled feedback. Voltage feed-forward with duty factor limiting provides high line rejection.

An internal EMI filter allows the converter to meet the conducted emissions requirements of MIL-STD-461C on the input power leads. A single-stage output filter reduces the typical output ripple to less than 50mV peak-to-peak.

Output current is limited under any load fault condition to approximately 125% of rated. An overload condition causes the converter output to behave like a constant current source with the output voltage dropping below nominal. The converter will resume normal operation when the load current is reduced below the current limit point. This protects the converter from both overload and short circuit conditions. The current limit point exhibits a slightly negative temperature coefficient to reduce the possibility of thermal runaway.

An external inhibit port is provided to control converter operation. The converter's operation is inhibited when this pin is pulled low. It is intended to be driven by an open collector logic device. The pin may be left open for normal operation and has a nominal open circuit voltage of 10.5V with respect to the input return (pin 2).

The output voltage of all models can be adjusted using a single external resistor.

Design Methodology

The M3L-Series was developed using a proven conservative design methodology which includes selecting radiation tolerance and established reliability components and fully de-rating to the requirements of MIL-STD-975 and MIL-STD-1547. Heavy de-rating of the power MOSFET gate and drain voltages minimize the possibility of SEGR and SEB. A magnetic feedback circuit is utilized instead of opto-couplers to minimize temperature, radiation and aging sensitivity. PSPICE was used extensively to predict and optimize circuit performance for both beginning and end-of-life. Thorough design analyses include Radiation Susceptibility (TREE), Stress, Thermal, and Reliability (MTBF).

Specifications

Absolute Maximum Ratings		Recommended Operating Conditions	
Input voltage range	-0.5V _{DC} to +60V _{DC}	Input voltage range	+16V _{DC} to +60V _{DC}
Output power	Internally limited	Input voltage range ¹	+16V _{DC} to +38V _{DC}
Lead temperature	+300°C for 10 seconds	Output power	0 to Max. Rated
Operating temperature	-55°C to +135°C	Operating temperature ²	-55°C to +125°C
Storage temperature	-55°C to +135°C	Operating temperature ¹	-55°C to +70°C

¹ Meets de-rating per MIL-STD-1547

² For operation at +125°C see table Note 13

Electrical Performance Characteristics

Parameter	Group A Subgroup	Conditions -55°C ≤ T _C ≤ +85°C V _{IN} = 28V DC ± 5%, C _L = 0 unless otherwise specified	Limits			Unit
			Min	Nom	Max	
Input voltage (V _{IN})			16	28	50	V
Output voltage (V _{OUT})						
M3L2803R3S	1	I _{OUT} = 100% rated load Note 4	3.27	3.30	3.33	V
M3L2805S	1		4.95	5.00	5.05	
M3L2812S	1		11.88	12.00	12.12	
M3L2815S	1		14.85	15.00	15.15	
M3L2805D	1		±4.95	±5.00	±5.05	
M3L2812D	1		±11.88	±12.00	±12.12	
M3L2815D	1		±14.85	±15.00	±15.15	
M3L2803R3S	2,3	I _{OUT} = 100% rated load Note 4	3.23		3.37	
M3L2805S	2,3		4.90		5.10	
M3L2812S	2,3		11.76		12.24	
M3L2815S	2,3		14.70		15.30	
M3L2805D	2,3		±4.90		±5.10	
M3L2812D	2,3		±11.76		±12.24	
M3L2815D	2,3		±14.70		±15.30	
Output power (P _{OUT})						
M3L2803R3S	1,2,3	V _{IN} = 16, 28, 50 Volts, Note 2	0		20	W
All Others			0		25	
Output current (I _{OUT})						
M3L2803R3S		V _{IN} = 16, 28, 50 Volts, Note 2	0		6.06	A
M3L2805S			0		5.00	
M3L2812S	1,2,3		0		2.08	
M3L2815S			0		1.67	
M3L2805D		Either Output, Note 3	0		4.00	
M3L2812D		Either Output, Note 3	0		1.67	
M3L2815D		Either Output, Note 3	0		1.33	
Line regulation (VR _{LINE})	1,2,3	V _{IN} = 16, 28, 50 Volts I _{OUT} = 0, 50%, 100% rated, Note 4	-0.5		0.5	
Load regulation (VR _{LOAD})	1,2,3	I _{OUT} = 0, 50%, 100% rated, Note 4 V _{IN} = 16, 28, 50 Volts	-1.0		1.0	%
Cross regulation (VR _{CROSS})						
M3L2805D		V _{IN} = 16, 28, 50 Volts	-5.0		5.0	%
M3L2812D	1,2,3	Duals only, Note 5	-3.0		3.0	
M3L2815D			-3.0		3.0	

For Notes to Electrical Performance Characteristics, refer to page 5

Electrical Performance Characteristics (continued)

Parameter	Group A Subgroup	Conditions -55°C ≤ T _C ≤ +85°C V _{IN} = 28V DC ± 5%, C _L = 0 unless otherwise specified	Limits			Unit
			Min	Nom	Max	
Input current, no load (I _{IN}) M3L2803R3S M3L2805S M3L2812S M3L2815S M3L2805D M3L2812D M3L2815D	1,2,3	I _{OUT} = 0, Pin 4 open			70 70 70 70 70 100 100	mA
Input current inhibited	1,2 3	Pin 4 shorted to pin 2			8.0 10	mA
Output ripple (V _{RIP}) M3L2803R3S M3L2805S M3L2812S M3L2815S M3L2805D M3L2812D M3L2815D	1,2,3	V _{IN} = 16, 28, 50 Volts I _{OUT} = 100% rated load Notes 4, 6			35 50 70 80 80 80 80	mVp-p
Switching frequency (F _S)	1,2,3	Sync. Input (Pin 4) open	425	500	575	kHz
Efficiency (E _{FF}) M3L2803R3S M3L2805S M3L2812S M3L2815S M3L2805D M3L2812D M3L2815D	1,2,3	I _{OUT} = 100% rated load Note 4	68 75 75 75 75 75 75	75 79 80 81 79 79 80		%
Enable input (Inhibit function) open circuit voltage drive current (sink) voltage range	1,2,3	Note 1	9.5 -0.5		11.5 500 50	V μA V
Current limit point Expressed as a percentage of full rated load current	1,2,3	V _{OUT} = 90% of Nominal, Note 4	105		130	%
Power dissipation, load fault (P _D)	1,2,3	Short Circuit, Overload, Note 8			14	W
Output response to step load changes (V _{TLD})	4,5,6	Half Load to/from Full Load, Notes 4,9	-300		300	mVpk
Recovery time, step load changes (T _{TLD})	4,5,6	Half Load to/from Full Load, Note 4,9,10			200	μs
Output response to step line changes (V _{TLN})	4,5,6	16V to/from 50V I _{OUT} = 100% rated load, Notes 1,4,11	-300		300	mVpk
Recovery time, step line changes (T _{TLN})	4,5,6	16V to/from 50V I _{OUT} = 100% rated load, Notes 1,4,10,11			200	μs

For Notes to Electrical Performance Characteristics, refer to page 5

Electrical Performance Characteristics (continued)

Parameter	Group A Subgroup	Conditions -55°C ≤ T _C ≤ +85°C V _{IN} = 28V DC ± 5%, C _L = 0 unless otherwise specified	Limits			Unit
			Min	Nom	Max	
Turn-on response Overshoot (V _{OS}) Turn-on Delay (T _{DLY})	4,5,6	No Load, Full Load Notes 4,12	2.0		500 10	mV ms
Capacitive load (C _L) M3L2803R3S M3L2805S M3L2812S M3L2815S M3L2805D M3L2812D M3L2815D	1	I _{OUT} = 100% rated load No effect on DC performance Notes 1, 4, 7 Each output on duals			2200 1000 180 120 500 90 60	μF
Line rejection	1	I _{OUT} = 100% rated load DC to 50 kHz, Notes 1, 4	40	50		dB
Isolation	1	Input to Output or Any Pin to Case except pin 3, test @ 500VDC	100			MΩ
Device weight					85	g
MTBF		MIL-HDBK-217F2, SF, 35°C	1.5 x 10 ⁶			Hr

Notes: Electrical Performance Characteristics Table

- Parameter is tested as part of design characterization or after design changes. Thereafter, parameter shall be guaranteed to the limits specified.
- Parameter verified during line and load regulation tests.
- Output load current must be distributed such that at least 20% of the total load current is being provided by one of the outputs.
- Load current split equally between outputs on dual output models.
- Cross regulation is measured with 20% rated load on output under test while changing the load on the other output from 20% to 80% of rated.
- Guaranteed for a D.C. to 20 MHz bandwidth. Tested using a 20 kHz to 10 MHz bandwidth using the circuit shown below.
- Capacitive load may be any value from 0 to the maximum limit without compromising dc performance. A capacitive load in excess of the maximum limit may interfere with the proper operation of the converter's overload protection, causing erratic behavior during turn-on.
- Overload power dissipation is defined as the device power dissipation with the load set such that V_{OUT} = 90% of nominal.
- Load step transition time ≤ 10 μs.
- Recovery time is measured from the initiation of the transient to where V_{OUT} has returned to within ±1% of its steady state value
- Line step transition time ≤ 100 μs.
- Turn-on delay time from either a step application of input power or a logic low to a logic high transition on the inhibit pin (pin 4) to the point where V_{OUT} = 90% of nominal.
- For operation at temperatures between +85°C and +125°C, de-rate the maximum output power linearly from 100% to 75%.

Circuit for Measuring Output Ripple Voltage

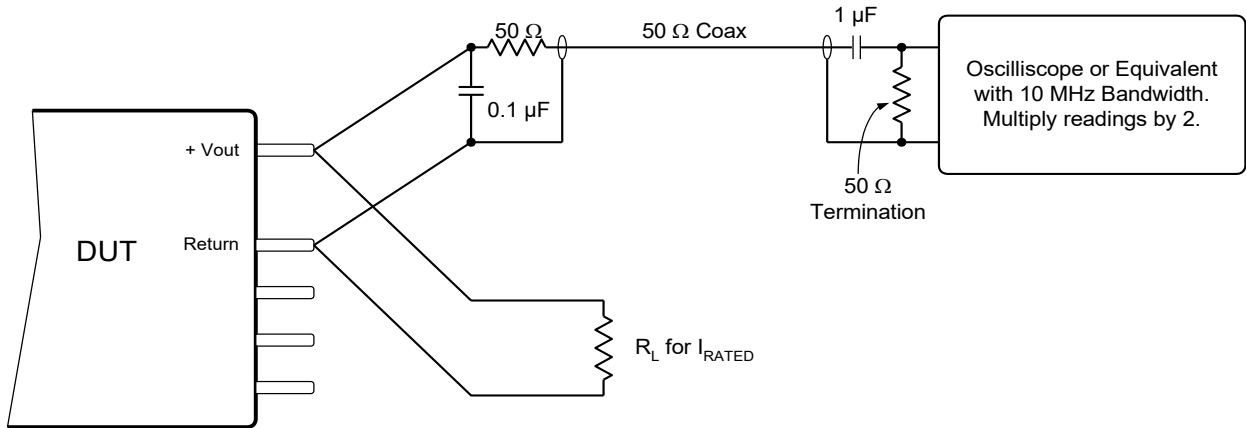

Radiation Performance Characteristics

Test	Conditions	Min	Typ	Highest Level Tested	Unit
Total Ionizing Dose (Gamma)	MIL-STD-883, Method 1019 Operating bias applied during exposure, Full Rated Load, $V_{IN} = 28V$	25	40	60	kRads(Si)
Single Event Effects SEU, SEL, SEGR, SEB	Heavy ions (LET) Operating bias applied during exposure, Full Rated Load, $V_{IN} = 28V$	37	82	82	MeV•cm ² /mg
Dose Rate (Gamma Dot) Temporary Saturation Survival	MIL-STD-883, Method 1023 Operating bias applied during exposure, Full Rated Load, $V_{IN} = 28V$	1E8 1E10		1.5E9	Rads (Si)/sec
Neutron Fluence	MIL-STD-883, Method 1017	3E12		8E12	Neutrons/cm ²

IR HiRel currently does not have a DLA Land and Maritime certified Radiation Hardness Assurance Program.

Figure 1. Block Diagram - Single Output

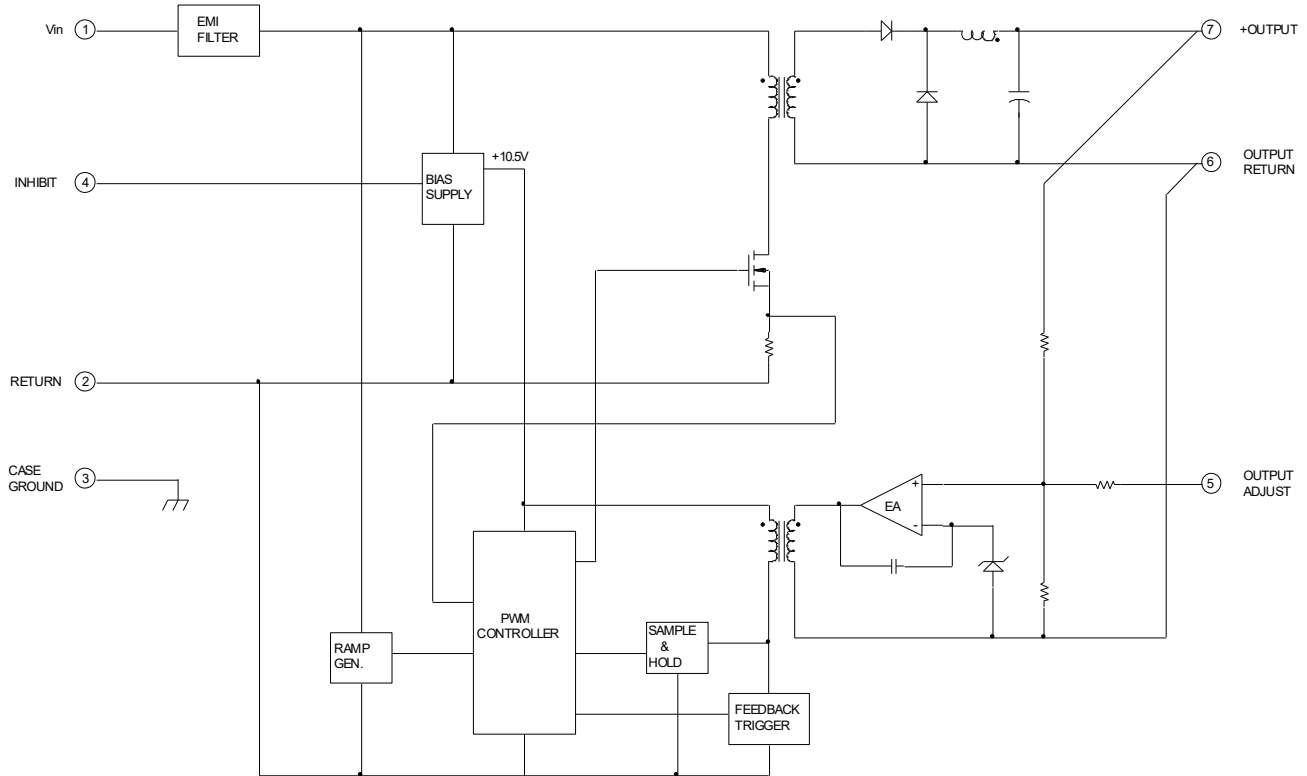

Figure 2. Block Diagram - Dual Output

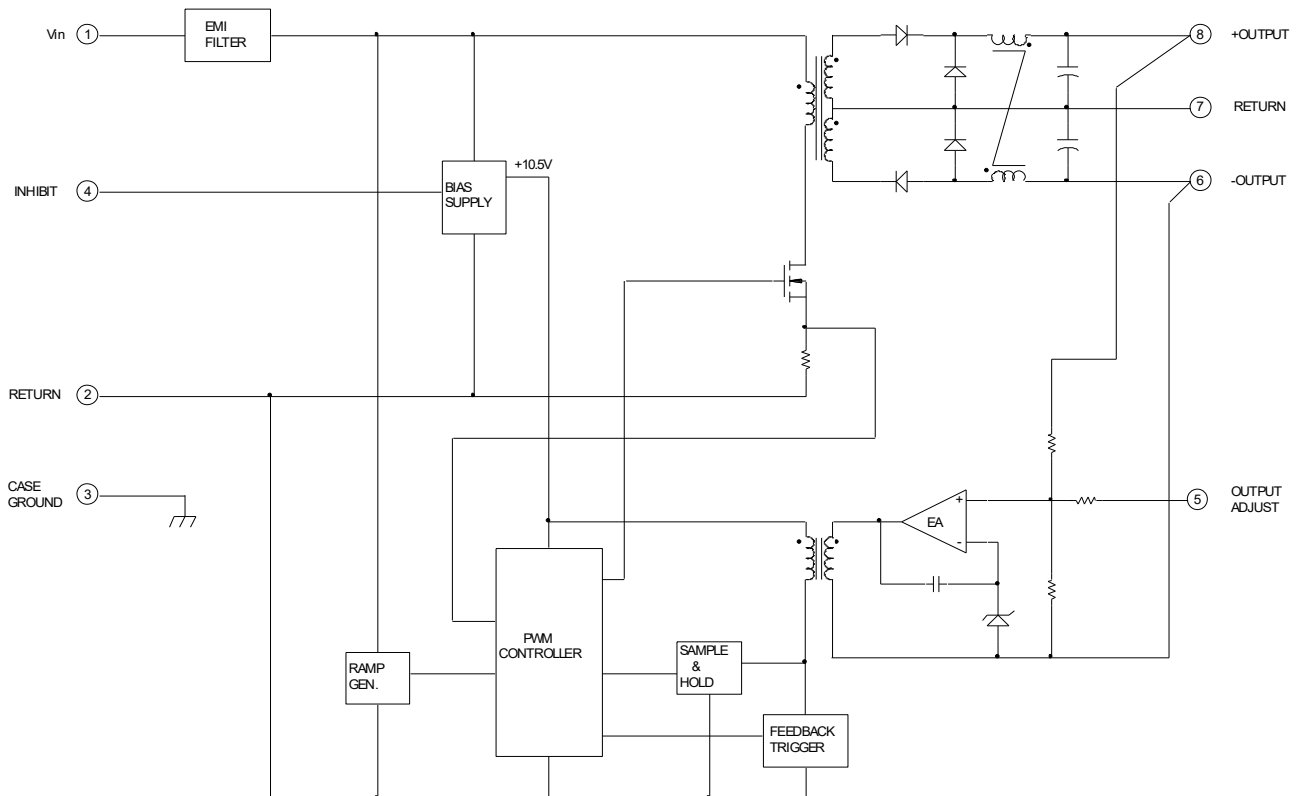

Figure 3. Conducted Emissions, Common Mode

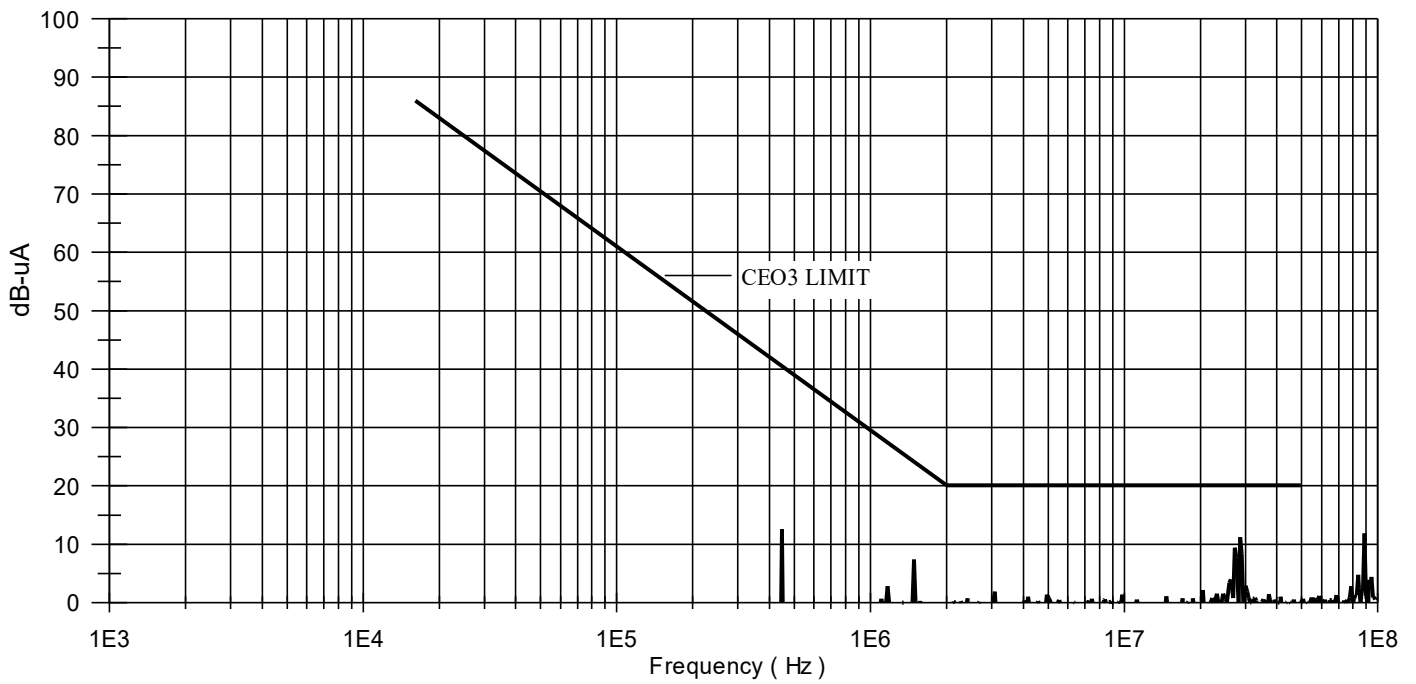

Figure 4. Conducted Emissions, Normal Mode

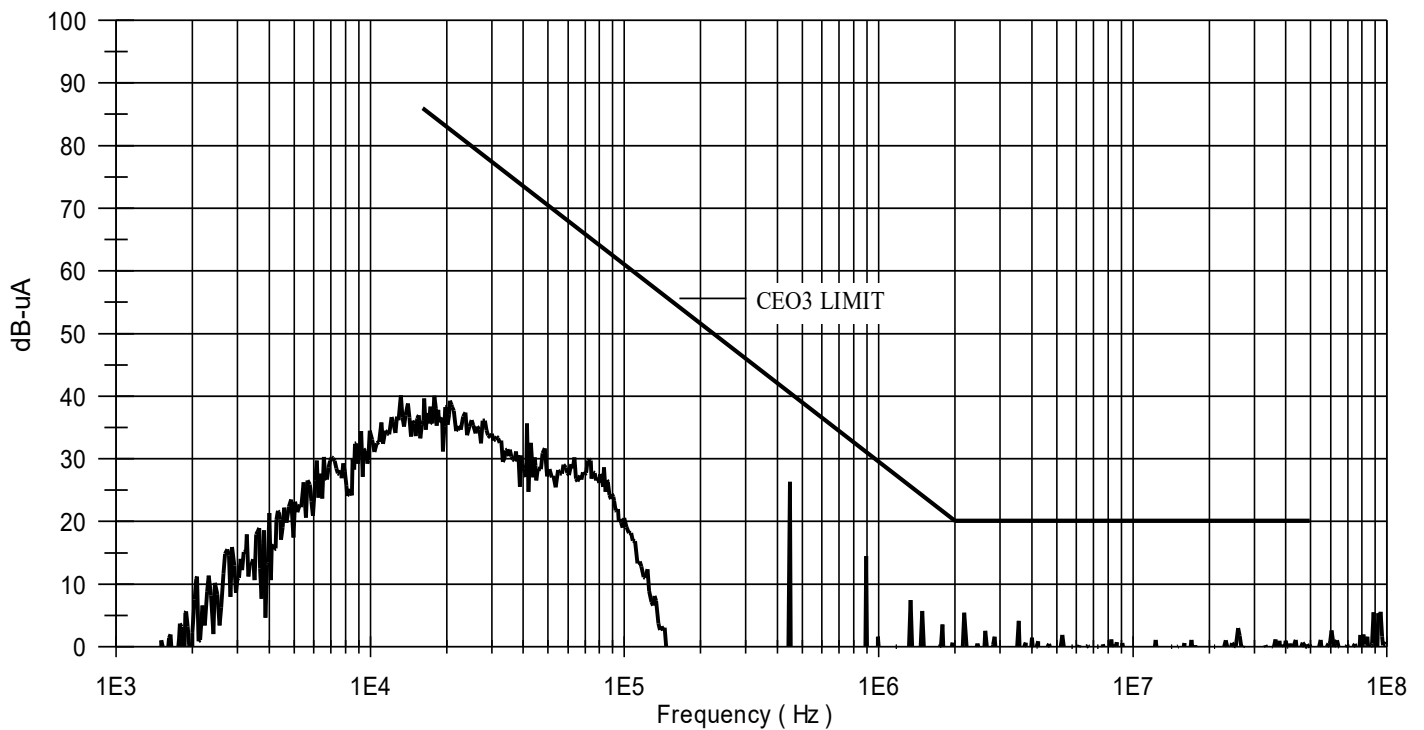

Figure 5. M3L2805S Line Rejection (CS01)

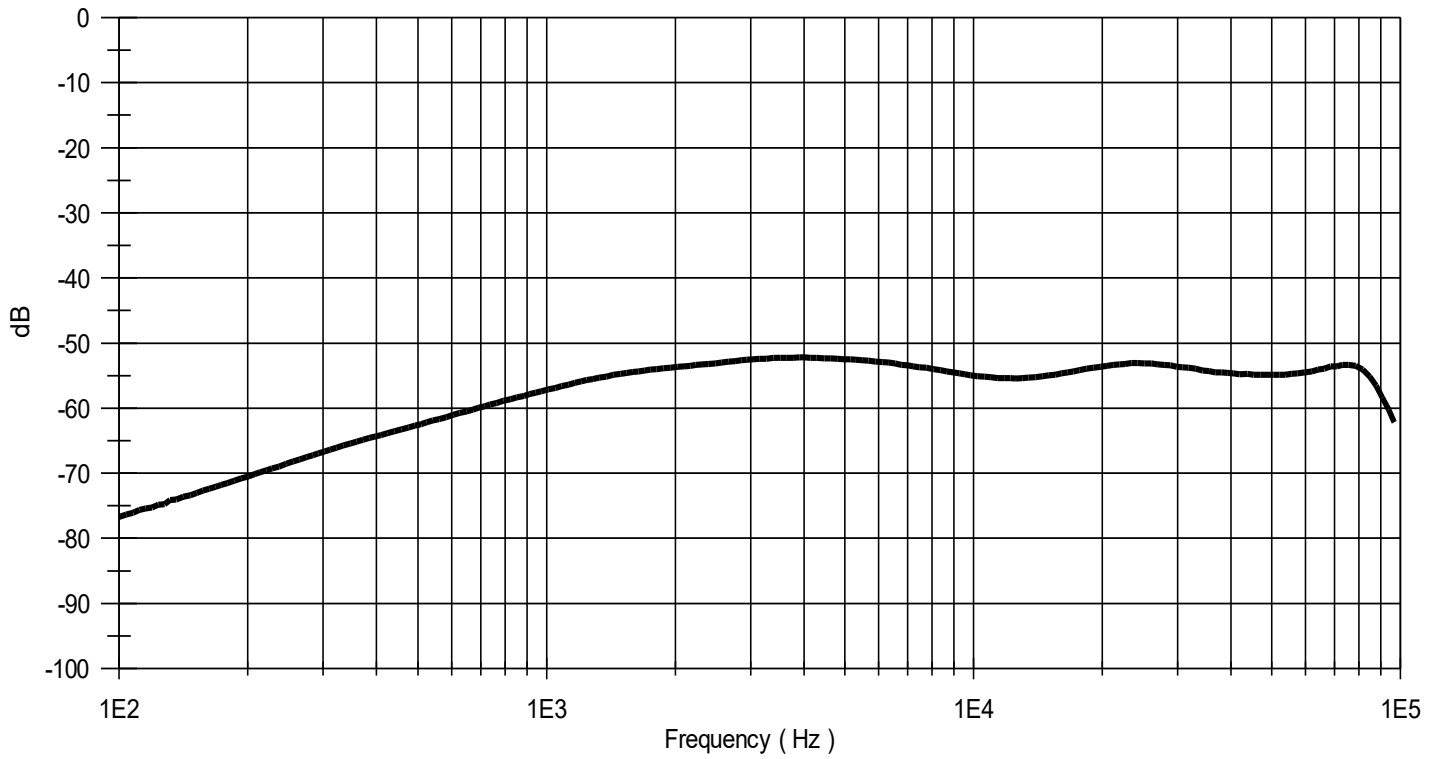

Figure 6. M3L2815D Line Rejection (CS01)

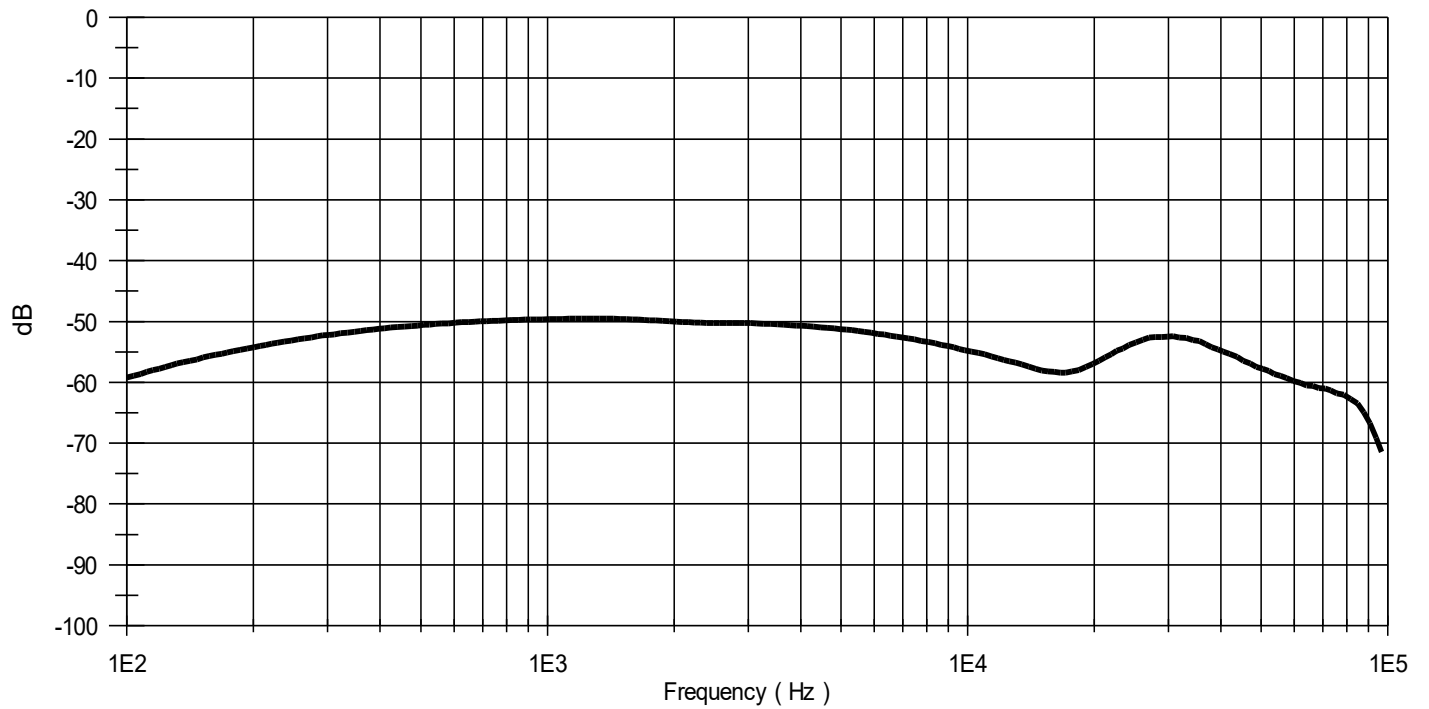
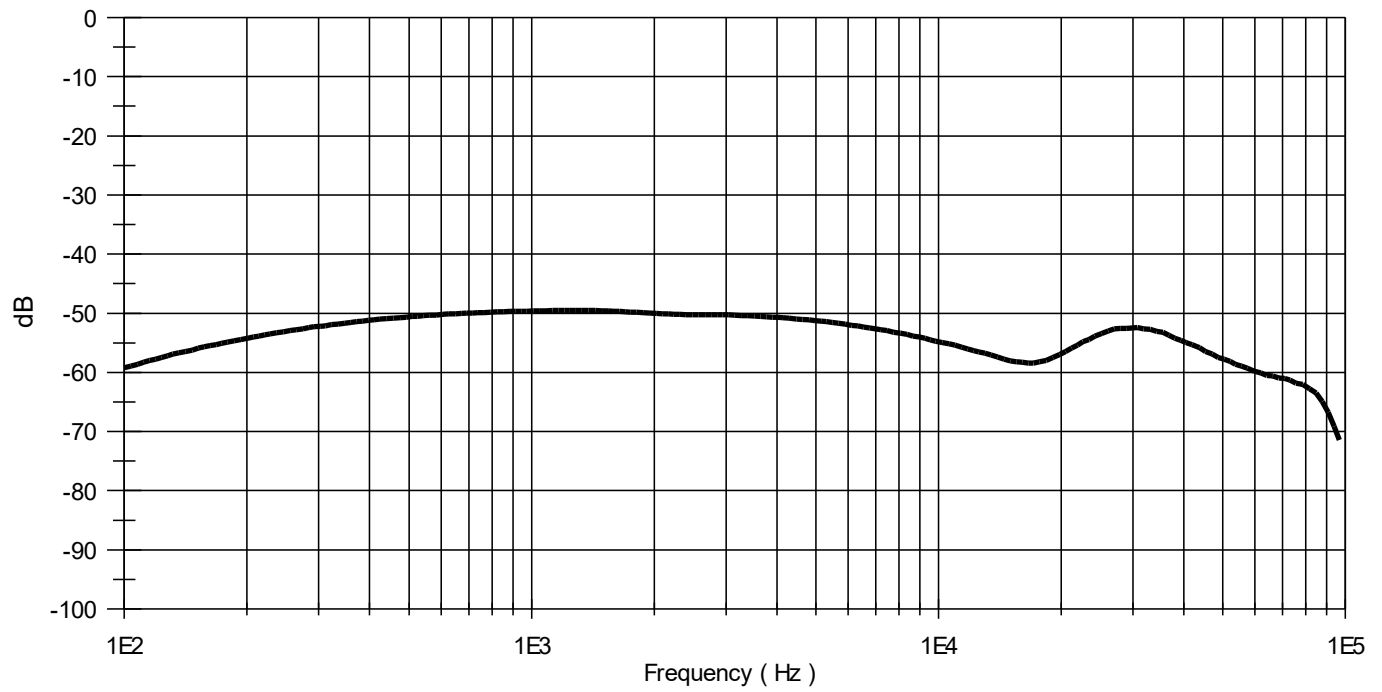
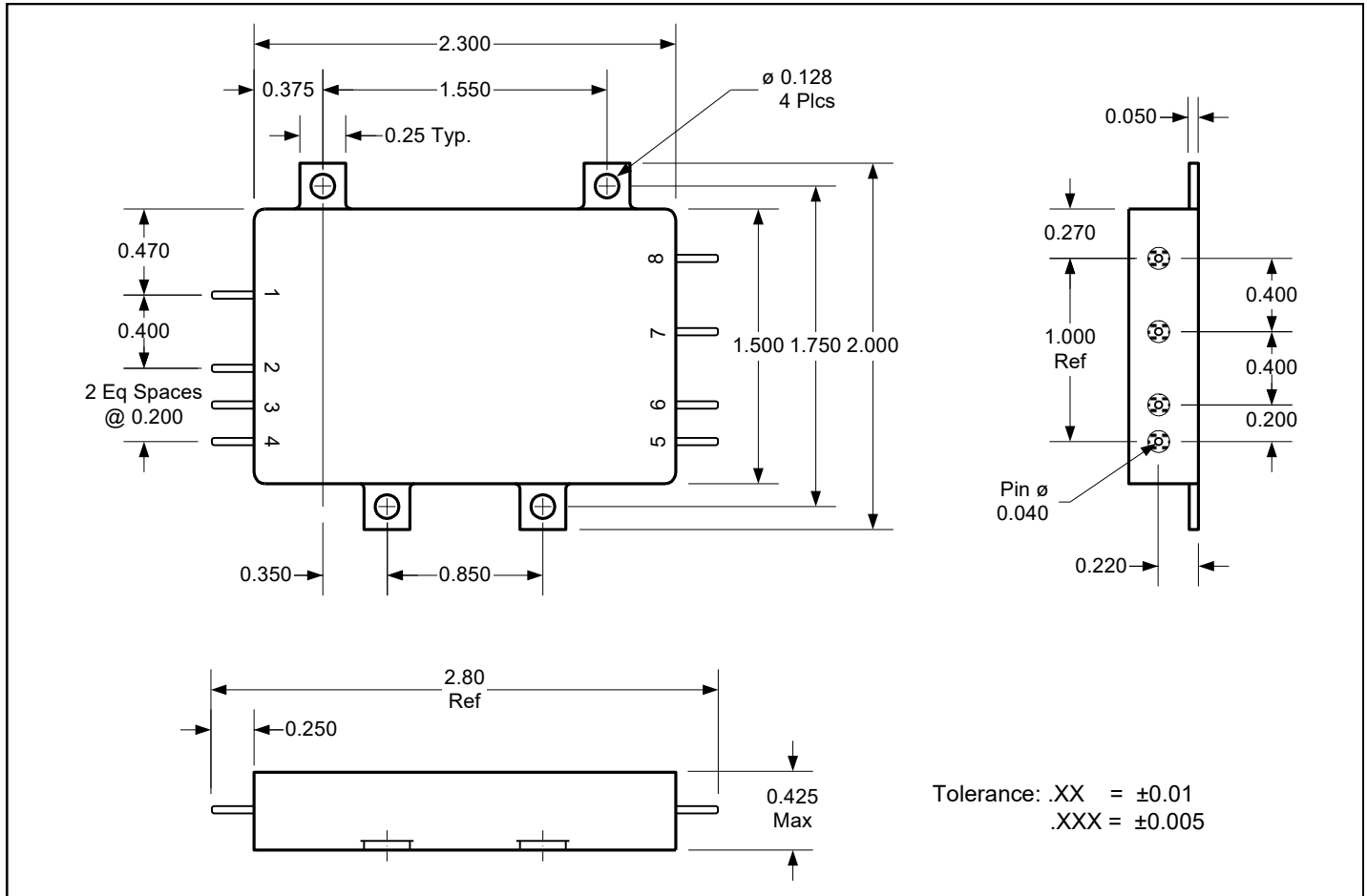

Figure 7. M3L2815D Line Rejections (CS01)



Mechanical Outline



Pin Designation (Single/Dual)

Pin #	Designation (Single)	Pin #	Designation (Dual)
1	INPUT (Vin)	1	INPUT (Vin)
2	INPUT RETURN	2	INPUT RETURN
3	CASE GROUND	3	CASE GROUND
4	INHIBIT	4	INHIBIT
5	OUTPUT ADJUST	5	OUTPUT ADJUST
6	OUTPUT RETURN	6	- OUTPUT (Vout)
7	+ OUTPUT (Vout)	7	OUTPUT RETURN
8	NC	8	+ OUTPUT (Vout)

Device Screening

Requirement	MIL-STD-883 Method	No Suffix	EM ①
Temperature Range	—	-55°C to +85°C	-55°C to +85°C
Element Evaluation	MIL-PRF-38534	Class H w/SEM	N/A
Non-Destructive Bond Pull	2023	Yes	N/A
Internal Visual	2017	Yes	①
Temperature Cycle	1010	Cond C	Cond C
Constant Acceleration	2001, Y1 Axis	3000 Gs	3000 Gs
PIND	2020	N/A	N/A
Burn-In	1015	160 hrs @ 125°C	48 hrs @ 125°C
Final Electrical (Group A)	MIL-PRF-38534 & Specification	-55°C, +25°C, +85°C	-55°C, +25°C, +85°C
PDA	MIL-PRF-38534	N/A	N/A
Seal, Fine and Gross	1014	A1, C	Cond A
Radiographic	2012	N/A	N/A
External Visual	2009	Yes	①

Notes:

- ① Best commercial practice.
- ② Any Engineering Model (EM) build with the “EM” Suffix shall only be form, fit and functional equivalent to its Flight Model (FM) counterpart, and it may not meet the radiation performance. The EM Model shall not be expected comply with MIL-PRF-38534 flight quality/workmanship standards, and configuration control. An EM build may use electrical equivalent commercial grade components. IR HiRel will provide a list of non-compliance items upon request.

Part Numbering
