

HIGH RELIABILITY RADIATION HARDENED DC-DC CONVERTER

+28V Input, Triple Output

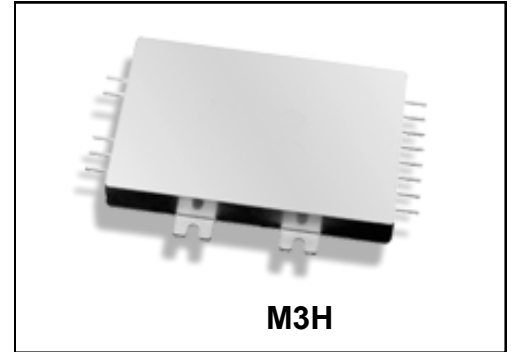
Description

M3H-Series is part of the International Rectifier HiRel family of products. The M3H-Series of DC-DC converters are radiation tolerant, high reliability devices designed for moderate radiation environments such as those encountered by low earth orbit satellites and launch vehicles. For higher radiation environments, the M3G-Series of DC-DC converters is recommended. System upgrades to higher radiation tolerance applications can be easily accommodated with the M3G-Series converters because they have the same mechanical outline and are pin compatible. For physically smaller, lower output power single and dual output applications the L-Series of DC-DC converters are recommended. Features of the M3H-Series include up to 40 watt output power, small size, low weight and a high tolerance to total ionizing dose, single event effects and environmental stresses such as temperature extremes, mechanical shock, and vibration. All components are fully de-rated to meet the requirements of MIL-STD-975 and MIL-STD-1547. Extensive documentation including Radiation Susceptibility, Thermal Analysis, Stress Analysis and MTBF are available.

The converters incorporate a fixed frequency single forward topology with magnetic feedback and an internal EMI filter. These converters are capable of meeting the conducted emissions and conducted susceptibility requirements of MIL-STD-461C without any additional components. All models include an external inhibit port and have an adjustable output voltage. They are enclosed in a hermetic 3.0" x 2.5" x 0.445" steel package and weigh less than 125 grams. The package utilizes rugged ceramic feed-through copper core pins and is sealed using parallel seam welding.

Manufactured in a facility fully qualified to MIL-PRF-38534, these converters are fabricated utilizing DLA Land and Maritime qualified processes. For available screening options, refer to device screening table in the data sheet.

Non-flight versions of the M3H-Series converters are available for system development purposes. Variations in electrical specifications and screening to meet custom requirements can be accommodated. Consult IR HiRel San Jose for special requirements.



Features

- Total Dose > 25 kRads(Si)
- SEE Hardened to LET up to 37 MeV.cm²/mg
- Internal EMI filter; Converter Capable of meeting MIL-STD-461C CE03 and CS01
- Low Weight < 125 grams
- Magnetically Coupled Feedback
- 18V to 50V Input Range (50V, 70V, and 120V Models Available)
- Up to 40W Output Power
- Triple Output Models Include +5 and ±12 or ±15V
- Main output isolated from dual outputs
- High Efficiency - to 82%
- -55°C to +125°C Operating Temperature Range
- 100MΩ @ 500VDC Isolation
- Under-Voltage Lockout
- Short Circuit and Overload Protection
- External Inhibit
- > 1,500,000 Hour MTBF

Applications

- Low Earth Orbit Satellites (LEO)
- Launch Vehicles

Circuit Description

The M3H-Series converters utilize a single forward topology with resonant reset. The nominal switching frequency is 500 kHz. Electrical isolation and tight output regulation are achieved through the use of a magnetically coupled feedback. Voltage feed-forward with duty factor limiting provides high line rejection.

An internal EMI filter allows the converter to meet the conducted emissions requirements of MIL-STD-461C on the input power leads. A two-stage output filter reduces the typical output ripple to less than 20mV peak-to-peak.

The main (+5 volt) output is regulated by the control loop and typically exhibits better than 1% regulation. The auxiliary (± 12 volt or ± 15 volt) outputs are maintained through tight coupling in the power transformer and main output filter inductor and typically exhibit better than 5% regulation. The main output and auxiliary outputs are isolated from each other. Output power is limited under any load fault condition to approximately 125% of rated. An overload condition causes the converter output to behave like a constant current source with the output voltage dropping below nominal. The converter will resume normal operation when the load current is reduced below the current limit point. This protects the converter from both overload and short circuit conditions. The current limit point exhibits a slightly negative temperature coefficient to reduce the possibility of thermal runaway.

An under-voltage lockout circuit prohibits the converter from operating when the line voltage is too low to maintain the output voltage. The converter will not start until the line voltage rises to approximately 17 volts and will shut down when the input voltage drops below 16 volts. The one volt of hysteresis reduces the possibility of line noise interfering with the converter's start-up and shut down.

An external inhibit port is provided to control converter operation. The converter's operation is inhibited when this pin is pulled low. It is intended to be driven by an open collector logic device. The pin may be left open for normal operation and has a nominal open circuit voltage of 10.5V with respect to the input return (pin 2).

Design Methodology

The M3H-Series was developed using a proven conservative design methodology which includes selecting radiation tolerant and established reliability components and fully de-rating to the requirements of MIL-STD-975 and MIL-STD-1547. Heavy de-rating of the power MOSFET gate and drain voltages minimize the possibility of SEGR and SEB. A magnetic feedback circuit is utilized instead of opto-couplers to minimize temperature, radiation and aging sensitivity. PSPICE was used extensively to predict and optimize circuit performance for both beginning and end-of-life. Thorough design analyses include Radiation Susceptibility (TREE), Stress, Thermal, and Reliability (MTBF).

Specifications

Absolute Maximum Ratings		Recommended Operating Conditions	
Input Voltage range	-0.5Vdc to +80V _{DC}	Input Voltage range	+18V _{DC} to +60V _{DC}
Output power	Internally limited	Input Voltage range ¹	+18V _{DC} to +50V _{DC}
Lead Temperature	+300°C for 10 seconds	Output power	0 to Max. Rated
Operating temperature	-55°C to +135°C	Operating temperature ²	-55°C to +125°C
Storage temperature	-55°C to +135°C	Operating temperature ¹	-55°C to +70°C

¹ Meets de-rating per MIL-STD-975

² For operation above +85°C see table Note 15

Electrical Performance Characteristics

Parameter	Group A Subgroup	Conditions -55°C ≤ T _C ≤ +85°C V _{IN} = 28V DC ± 5%, C _L = 0 unless otherwise specified	Limits			Unit
			Min	Nom	Max	
Input voltage	1,2,3	Note 2	18	28	50	V
Output voltage (V _{OUT}) (main) 2812T (aux.) 2815T (aux.)	1	I _{OUT} = 100% rated load, Note 5	4.98 ±11.50 ±14.60	5.00 ±11.80 ±14.90	5.02 ±12.10 ±15.20	V
(main) 2812T (aux.) 2815T (aux.)	2,3	I _{OUT} = 100% rated load, Note 5	4.93 ±11.30 ±14.40		5.07 ±12.30 ±15.40	
Output power (P _{OUT})	1,2,3	V _{IN} = 18, 28, 50 Volts, Note 2	0		40	W
Output current (I _{OUT}) (main) 2812T (aux.) 2815T (aux.)	1,2,3	V _{IN} = 18, 28, 50 Volts, Notes 2,3,4,5	400 83 67		4000 ±833 ±667	mA
Line regulation (VR _{LINE}) (main) 2812T (aux.) 2815T (aux.)	1,2,3	V _{IN} = 18, 28, 50 Volts I _{OUT} = 10%, 50%, 100% rated Notes 5, 14	-10 -200 -200		10 200 200	mV
Load regulation (VR _{LOAD}) (main) 2812T (aux.) 2815T (aux.)	1,2,3	I _{OUT} = 10%, 50%, 100% rated V _{IN} = 18, 28, 50 Volts Notes 5,13	-50 -400 -500		50 400 500	mV
Cross regulation (VR _{CROSS}) 2812T (aux.) 2815T (aux.)	1,2,3	V _{IN} = 18, 28, 50 Volts I _{OUT} = 2.5A to 1A and 2.5A to 4A on main and ± half rated on aux. outputs	-3.5 -3.0		3.5 3.0	%
Input current (I _{IN})	1,2,3	I _{OUT} = 0, Pin 3 open Pin 3 shorted to pin 2			80 8.0	mA
Output ripple (VR _{RIP}) (main) 2812T (aux.) 2815T (aux.)	1,2,3	V _{IN} = 18, 28, 50 Volts I _{OUT} = 100% rated load, Notes 5, 6		25 30 30	50 60 75	mVp-p
Switching frequency (Fs)	1,2,3	Sync. Input (Pin 4) open	450	500	550	kHz
Efficiency (E _{ff})	1,2,3	I _{OUT} = 100% rated load; Note 5	75	79		%
Inhibit input open circuit voltage drive current (sink) voltage range	1,2,3	Note 1	3.0 -0.5		5.0 100 50	V μA V

For Notes to Electrical Performance Characteristics, refer to page 4.

Electrical Performance Characteristics (continued)

Parameter	Group A Subgroup	Conditions -55°C ≤ T _C ≤ +125°C V _{IN} = 28V DC ± 5%, C _L = 0 unless otherwise specified	Limits			Unit
			Min	Nom	Max	
Current limit point Expressed as a percentage of full rated output power	1,2,3	V _{OUT} = 90% of Nominal, Notes 5, 9			135	%
Power dissipation, load fault (P _D)	1,2,3	Short Circuit, Overload			18	W
Output response to step load changes (V _{TLD})	4,5,6	Half Load to/from Full Load, Notes 5, 10, 14	-300		300	mVpk
Recovery time, step load changes (T _{TLD})	4,5,6	Half Load to/from Full Load, Notes 10, 11, 14			200	μs
Output response to step line changes (V _{TLN})	4,5,6	18V to/from 50V I _{OUT} = 100% rated load, Notes 1, 5, 12	-300		300	mVpk
Recovery time, step line changes (T _{TLN})	4,5,6	18V to/from 50V I _{OUT} = 100% rated load, Notes 1, 5, 11, 12			200	μs
Turn-on response Overshoot (V _{OS}) (main) (aux.)	4,5,6	10% Load, Full Load; Notes 5, 12, 13			10 10	%
Turn-on delay (T _{DLY})	4,5,6	Notes 5, 12, 13	1.0		10	ms
Capacitive load (C _L) (main) (Each aux. output)	1	I _{OUT} = 100% rated load, No effect on DC performance, Notes 1, 5, 7, 8			1000 200	μF
Line rejection	1	I _{OUT} = 100% rated load DC to 50kHz, Notes 1, 5	40	60		dB
Isolation	1	Input to Output or Any Pin to Case except pin 10, test @ 500VDC	100			MΩ
Device weight					125	g
MTBF		MIL-HDBK-217F2, SF, 35°C	1.5 x 10 ⁶			Hrs

Notes: Electrical Performance Characteristics Table

- Parameter is tested as part of design characterization or after design changes. Thereafter, parameter shall be guaranteed to the limits specified.
- Parameter verified during line and load regulation tests.
- Although operation with no load is permissible, **light** loading on the main (+5 volt) output may cause the output voltage of the auxiliary outputs (±12 volt or ±15 volt) to drop out of regulation. It is therefore recommended that at least 200 mA or 20 percent of the total output power, whichever is greater, be taken from the main (+5 volt) output.
- Although operation with no load is permissible, **heavy** loading on the main (+5 volt) output may cause the output voltage of the auxiliary outputs (±12 volt or ±15 volt) to rise out of regulation. It is therefore recommended that at least 50 mA or 20 percent of the total output power, whichever is greater, be taken from the auxiliary (±12 volt or ±15 volt) outputs.
- Unless otherwise specified, "Rated" load is 20W on the main (+5 volt) output and 10 watts each on the auxiliary (±12 volt or ±15 volt) outputs. Load currents of up to 5A and ±1A on the main and auxiliary outputs respectively are acceptable as long as the total output power does not exceed 40 watts.
- Guaranteed for a D.C. to 20 MHz bandwidth. Tested using a 20 kHz to 10 MHz bandwidth.
- Capacitive load may be any value from 0 to the maximum limit without compromising dc performance.
- A capacitive load in excess of the maximum limit may interfere with the proper operation of the converter's overload protection, causing erratic behavior during turn-on.
- Overload power threshold is defined as the load set point such that V_{OUT} = 90% of nominal.
- Load step transition time ≤ 10 μs.
- Recovery time is measured from the initiation of the transient to where V_{OUT} has returned to within ±1% of its steady state value.
- Line step transition time ≤ 100 μs.
- Turn-on delay time from either a step application of input power or a logic low to a logic high transition on the inhibit pin (pin 3) to the point where V_{OUT} = 90% of nominal.
- Load is varied for output under test while the remaining outputs are loaded at 50% of rated. Regulation relative to output voltage at 50% rated load
- For operation @ temperatures between +85°C and +125°C, de-rate the maximum input voltage linearly from 60V to 40V and the maximum output power linearly from 100% to 75%.

Radiation Performance Characteristics

Test	Conditions	Min	Typ	Highest Level Tested	Unit
Total Ionizing Dose (Gamma)	MIL-STD-883, Method 1019 Operating bias applied during exposure, Full Rated Load, $V_{IN} = 28V$	25	40	60	kRads(Si)
Single Event Effects SEU, SEL, SEGR, SEB	Heavy ions (LET) Operating bias applied during exposure, Full Rated Load, $V_{IN} = 28V$	37	82	82	MeV•cm ² /mg
Dose Rate (Gamma Dot) Temporary Saturation Survival	MIL-STD-883, Method 1023 Operating bias applied during exposure, Full Rated Load, $V_{IN} = 28V$	1E8 1E10		1.5E9	Rads (Si)/sec
Neutron Fluence	MIL-STD-883, Method 1017	3E12		8E12	Neutrons/cm ²
Proton Fluence	$E > 10MeV$	TBD		N/A	Protons /cm ²

IR HiRel currently does not have a DLA Land and Maritime certified Radiation Hardness Assurance Program.

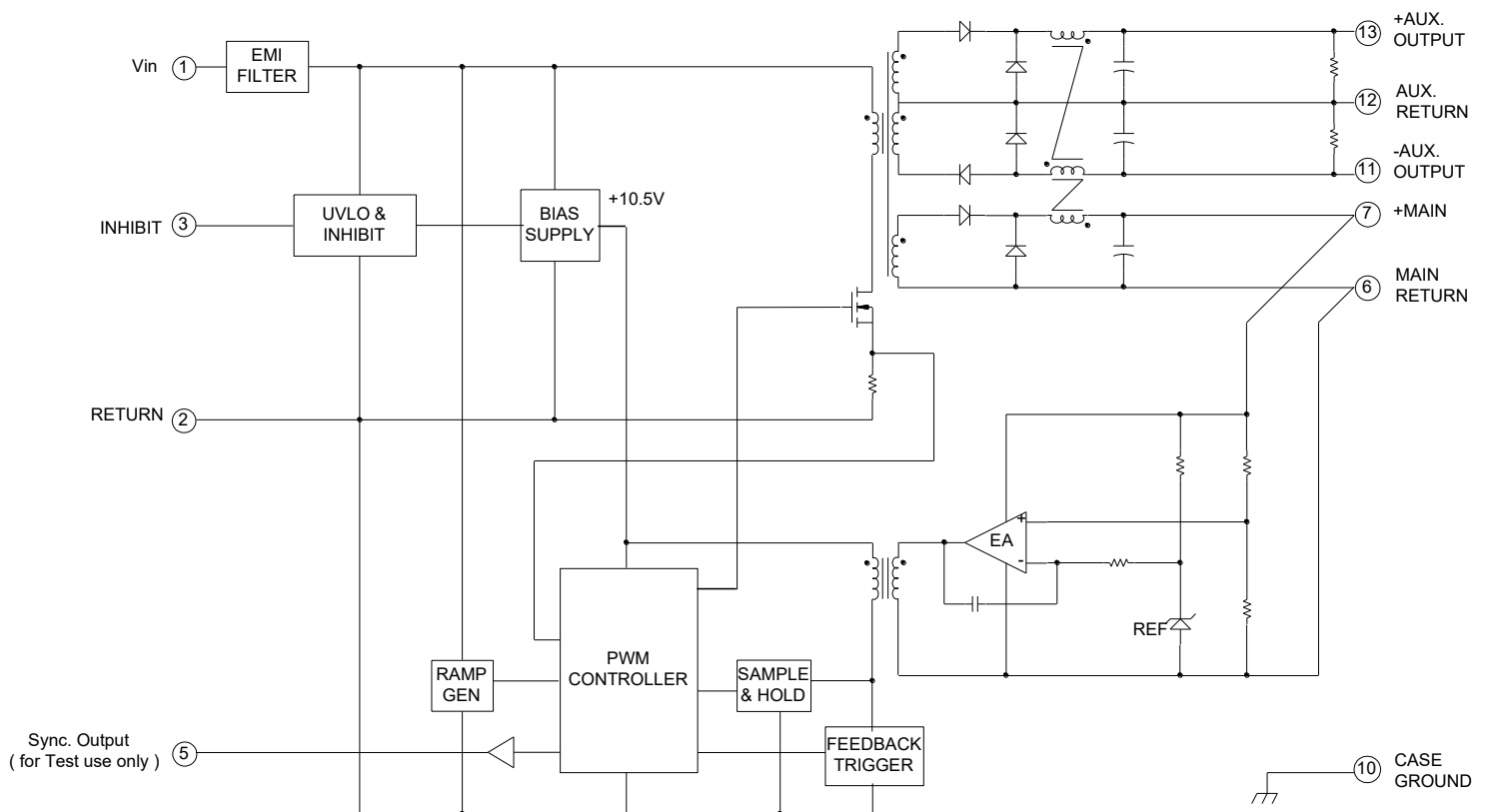
Figure 1. Block Diagram


Figure 2. $\pm 12V$ Load Regulation Vs 5V Load

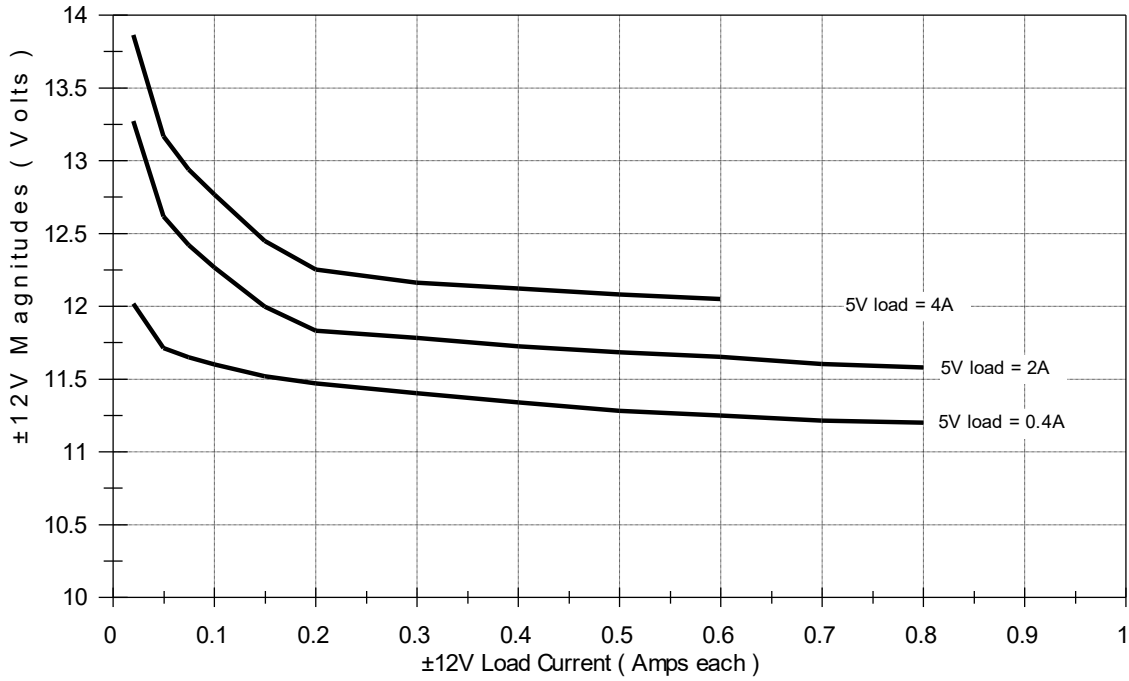
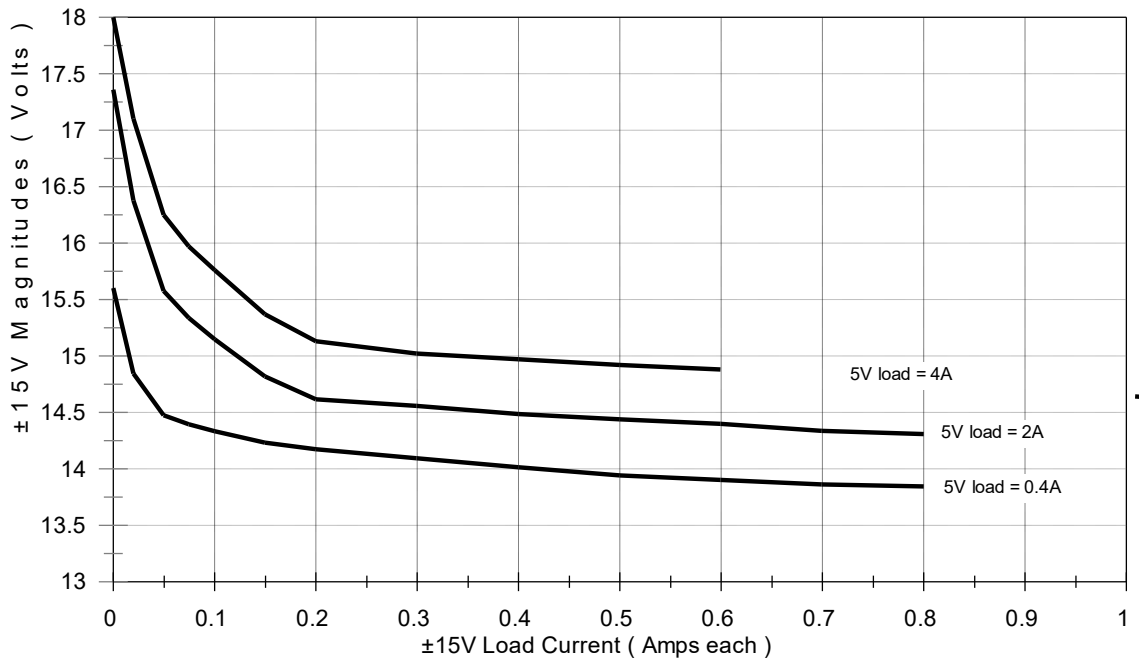
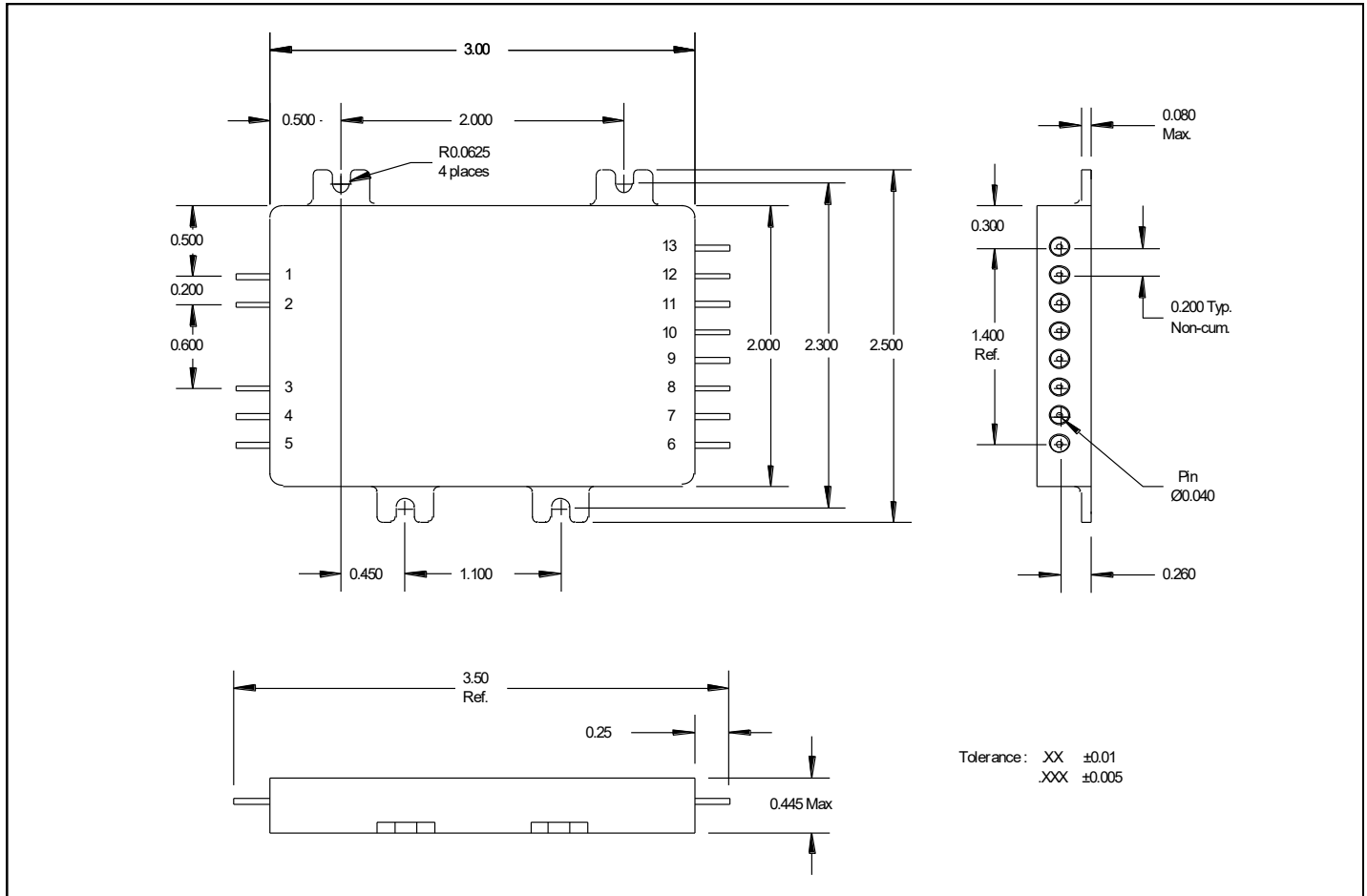


Figure 3. $\pm 15V$ Load Regulation Vs 5V Load



Mechanical Outline



Pin Designation

Pin #	Designation	Pin #	Designation
1	+ Vin	8	NC
2	Input Return	9	NC
3	Inhibit	10	Case Ground
4	NC	11	- Aux Output
5	Sync. Output (T.P.)	12	Aux Output Return
6	Main Return	13	+ Aux Output
7	+ Main Return		

Device Screening

Requirement	MIL-STD-883 Method	No Suffix	EM ②
Temperature Range	—	-55°C to +85°C	-55°C to +85°C
Element Evaluation	MIL-PRF-38534	Class H w/SEM	N/A
Non-Destructive Bond Pull	2023	Yes	N/A
Internal Visual	2017	Yes	①
Temperature Cycle	1010	Cond C	Cond C
Constant Acceleration	2001, Y1 Axis	3000 Gs	3000 Gs
PIND	2020	N/A	N/A
Burn-In	1015	160 hrs @ 125°C	48 hrs @ 125°C
Final Electrical (Group A)	MIL-PRF-38534 & Specification	-55°C, +25°C, +85°C	-55°C, +25°C, +85°C
PDA	MIL-PRF-38534	2%	N/A
Seal, Fine and Gross	1014	A1, C	Cond A
Radiographic	2012	N/A	N/A
External Visual	2009	Yes	①

Notes:

- ① Best commercial practice.
- ② Any Engineering Model (EM) build with the “EM” Suffix shall only be form, fit and functional equivalent to its Flight Model (FM) counterpart, and it may not meet the radiation performance. The EM Model shall not be expected comply with MIL-PRF-38534 flight quality/workmanship standards, and configuration control. An EM build may use electrical equivalent commercial grade components. IR HiRel will provide a list of non-compliance items upon request.

Part Numbering

