

HYBRID-HIGH RELIABILITY RADIATION HARDENED DC-DC CONVERTER

28V Input, Single/Dual Output

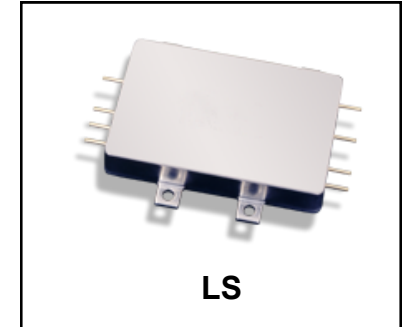

Description

The LS-Series of DC-DC converters are, high reliability devices designed for hostile radiation hardened environments. The LS-Series provide up to 30 watts output power, small size, low weight, integrated EMI filtering and a high tolerance to environmental stresses such as radiation, temperature extremes, mechanical shock, and vibration. Extensive documentation including, thermal analysis, stress analysis and reliability predictions are available.

The LS-Series of converters incorporate a fixed frequency single forward topology with magnetic feedback and an internal EMI filter. These converters are capable of meeting the conducted emissions requirements of MIL-STD-461C without any additional components. All models include an external inhibit port and have an adjustable output voltage. They are enclosed in a hermetic 1.5" x 2.3" x 0.425" steel package and weigh less than 80 grams. The package utilizes rugged ceramic feed-through copper core pins and is sealed using parallel seam welding.

The LS-Series of DC-DC converters provide same mechanical outline, power ratings, for backward pin compatibility, to their lower radiation tolerant counterpart M3L and Military series ATS DC-DC converters. The common platform design allows for similarity between military and space system architectures. For higher output power applications the HM, M3H and M3G-Series of DC-DC converters are recommended.

Manufactured in a facility fully qualified to MIL-PRF-38534, these converters are fabricated utilizing DLA Land and Maritime qualified processes. For available screening options, refer to device screening table in the data sheet.

Variations in electrical specifications and screening to meet custom requirements can be accommodated.

Features

- 18 to 40V DC Input Range
- Total Ionization Dose > 100 kRad(Si)
- SEE Hardened to LET (Heavy Ions) up to 82 MeV•cm²/mg (SEU, SEL, SEGB, SEGR)
- Internal EMI filter; Converter Capable of meeting MIL-STD-461C CE03
- Low Weight, < 80 grams
- Magnetically Coupled Feedback
- Up to 30W Output Power
- Single and Dual Output Models Include 1.5, 2.5, 3.3, 5, 12, 15, ±5, ±12 and ±15V
- High Efficiency - to 83%
- 100MΩ @ 500V_{DC} Isolation
- Under Voltage Protection
- Short Circuit and Overload Protection
- Adjustable Output Voltage
- External Inhibit
- > 4,000,000 Hour MTBF (SF)
- Standard Microcircuit Drawings Available

Applications

- Geo Synchronous Satellite
- Low Earth Orbit
- Deep Space Probe
- Communication and Display Systems
- Payload and Experiment LVPS

Circuit Description

The LS-Series converters utilize a single-ended forward topology with resonant reset. The nominal switching frequency is 500 kHz. Electrical isolation and tight output regulation are achieved through the use of a magnetically coupled feedback. Voltage feed-forward with duty factor limiting provides high line rejection and protection against output over voltage in the event of an internal control loop failure.

An internal EMI filter allows the converter to meet the conducted emissions requirements of MIL-STD-461C on the input power leads.

Output current is limited under any load fault condition to approximately 125% of rated. An overload condition causes the converter output voltage to drop below nominal. The converter will resume normal operation when the load current is reduced below the current limit point. This protects the converter from both overload and short circuit conditions. The current limit point exhibits a slightly negative temperature coefficient to reduce the possibility of thermal runaway.

An external inhibit port is provided to control converter operation. The converter's operation is inhibited when this pin is pulled low. It is intended to be driven by an open collector logic device. The pin may be left open for normal operation and has a nominal open circuit voltage of 11V with respect to the input return (pin 2).

The output voltage of all models can be adjusted using a single external resistor.

Design Methodology

The LS-Series was developed using a proven conservative design methodology derived from other space level designs that includes selection of established reliability components and fully de-rating to the requirements of MIL-STD-975 except for the CDR type of capacitors, a capacitor with 50V rating is used for in-circuit voltage stress of less than 10V. A magnetic feedback circuit is utilized instead of opto-couplers to minimize temperature, aging and radiation sensitivity. PSPICE was used extensively to predict and optimize circuit performance for both beginning and end-of-life. Thorough design analyses include stress, thermal, and reliability (MTBF).

Specifications

| Absolute Maximum Ratings | | Recommended Operating Conditions | |
|----------------------------|---|---|--|
| Input Voltage range | -0.5V _{DC} to +60V _{DC} | Input Voltage range ¹ | +18V _{DC} to +40V _{DC} |
| Output power | Internally limited | Output power | 0 to Max. Rated |
| Lead Temperature | +300°C for 10 seconds | Operating case temperature | -55°C to +85°C |
| Operating Case temperature | -55°C to +125°C (Note 13) | Operating case temperature ² | -55°C to +70°C |
| Storage temperature | -55°C to +135°C | | |

1. Meets MIL-STD-1547, MIL-STD-975 and NASA EEE-INST-002 up to the input voltage at 38.6V.

2. Meets de-rating per MIL-STD-975

Electrical Performance Characteristics

| Parameter | Group A Subgroup | Conditions -55°C ≤ T _C ≤ +85°C V _{IN} = 28V DC ± 5%, C _L = 0 unless otherwise specified | Limits | | | Unit | |
|------------------------------------|------------------|---|--------|-----------------------|--------|------|-----|
| | | | Min | Nom | Max | | |
| Input Voltage | | | 18 | 28 | 40 | V | |
| Output Voltage (V _{OUT}) | | | | | | | |
| LS2801R5S | 1 | I _{OUT} = 100% rated load Note 4 | 1.47 | 1.50 | 1.53 | V | |
| LS2802R5S | 1 | | 2.47 | 2.50 | 2.53 | | |
| LS2803R3S | 1 | | 3.27 | 3.30 | 3.33 | | |
| LS2805S | 1 | | 4.95 | 5.00 | 5.05 | | |
| LS2812S | 1 | | 11.88 | 12.00 | 12.12 | | |
| LS2815S | 1 | | 14.85 | 15.00 | 15.15 | | |
| LS2805D | 1 | | ±4.95 | ±5.00 | ±5.05 | | |
| LS2812D | 1 | | ±11.88 | ±12.00 | ±12.12 | | |
| LS2815D | 1 | | ±14.85 | ±15.00 | ±15.15 | | |
| LS2801R5S | 2,3 | I _{OUT} = 100% rated load Note 4, 14 | 1.43 | | 1.57 | V | |
| LS2802R5S | 2,3 | | 2.43 | | 2.57 | | |
| LS2803R3S | 2,3 | | 3.23 | | 3.37 | | |
| LS2805S | 2,3 | | 4.90 | | 5.10 | | |
| LS2812S | 2,3 | | 11.76 | | 12.24 | | |
| LS2815S | 2,3 | | 14.70 | | 15.30 | | |
| LS2805D | 2,3 | | ±4.90 | | ±5.10 | | |
| LS2812D | 2,3 | | ±11.76 | | ±12.24 | | |
| LS2815D | 2,3 | | ±14.70 | | ±15.30 | | |
| Output power (P _{OUT}) | | | | | | | |
| LS2801R5S | 1,2,3 | V _{IN} = 18, 28, 40 Volts, Note 2 | 0 | | 12 | W | |
| LS2802R5S | | | 0 | | 20 | | |
| LS2803R3S | | | 0 | | 25 | | |
| All Others | | | 0 | | 30 | | |
| Output current (I _{OUT}) | | | | | | | |
| LS2801R5S | 1,2,3 | V _{IN} = 18, 28, 40 Volts, Note 2 | 0 | | 8.0 | A | |
| LS2802R5S | | | 0 | | 8.0 | | |
| LS2803R3S | | | 0 | | 7.57 | | |
| LS2805S | | | 0 | | 6.0 | | |
| LS2812S | | | 0 | | 2.5 | | |
| LS2815S | | | 0 | | 2.0 | | |
| LS2805D | | | 0 | Either Output, Note 3 | 0 | | 4.8 |
| LS2812D | | | 0 | Either Output, Note 3 | 0 | | 2.3 |
| LS2815D | | | 0 | Either Output, Note 3 | 0 | | 1.6 |

For Notes to Electrical Performance Characteristics, refer to page 6.

Electrical Performance Characteristics (continued)

| Parameter | Group A Subgroup | Conditions -55°C ≤ T _C ≤ +85°C V _{IN} = 28V DC ± 5%, C _L = 0 unless otherwise specified | Limits | | | Unit |
|--|------------------|---|--|--|--|-------|
| | | | Min | Nom | Max | |
| Line regulation (VR _{LINE}) | 1,2,3 | V _{IN} = 18, 28, 40 Volts I _{OUT} = 0, 50%, 100% rated, Note 4 | -0.5 | | 0.5 | % |
| Load regulation (VR _{LOAD}) LS2801R5S LS2802R5S All others | 1,2,3 | V _{IN} = 18, 28, 40 Volts I _{OUT} = 0, 50%, 100% rated, Note 4 | -2.0 -1.2 -1.0 | | 2.0 1.2 1.0 | % |
| Cross regulation (VR _{CROSS}) LS2805D LS2812D LS2815D | 1,2,3 | V _{IN} = 18, 28, 40 Volts Duals only, Note 5 | -5.0 -3.0 -3.0 | | 5.0 3.0 3.0 | % |
| Input Current, no load (I _{IN}) LS2801R5S LS2802R5S LS2803R3S LS2805S LS2812S LS2815S LS2805D LS2812D LS2815D | 1,2,3 | I _{OUT} = 0, Pin 4 open | | | 60 60 60 70 70 70 70 100 100 | mA |
| Input current inhibited | 1,2,3 | Pin 4 shorted to pin 2 | | | 8.0 | mA |
| Output Ripple, (V _{RIP}) LS2801R5S LS2802R5S LS2803R3S LS2805S LS2812S LS2815S LS2805D LS2812D LS2815D | 1,2,3 | V _{IN} = 18, 28, 40 Volts I _{OUT} = 100% rated load Notes 4, 6 | | | 35 35 35 50 70 80 80 80 80 | mVp-p |
| Switching frequency (F _S) | 1,2,3 | | 425 | 500 | 575 | kHz |
| Efficiency (E _{FF}) LS2801R5S LS2802R5S LS2803R3S LS2805S LS2812S LS2815S LS2805D LS2812D LS2815D | 1,2,3 | I _{OUT} = 100% rated load Note 4 | 61 68 72 78 78 78 79 79 79 | 64 71 76 82 82 82 83 83 83 | | % |

For Notes to Electrical Performance Characteristics, refer to page 6.

Electrical Performance Characteristics (continued)

| Parameter | Group A Subgroup | Conditions -55°C ≤ T _C ≤ +85°C V _{IN} = 28V DC ± 5%, C _L = 0 unless otherwise specified | Limits | | | Unit |
|--|------------------|---|-------------|-----|---|--|
| | | | Min | Nom | Max | |
| Enable Input (Inhibit Function) open circuit voltage drive current (sink) voltage range | | Note 1 | 9.5 -0.5 | | 12 5.0 50 | V mA V |
| Current Limit Point Expressed as a percentage of full rated load current | 1,2,3 | V _{OUT} = 90% of Nominal, Note 4 | 105 | | 145 | % |
| Power dissipation, load fault (P _D) | 1,2,3 | Short Circuit, Overload, Note 8 | | | 14 | W |
| Output response to step load changes (V _{TLD}) | 4,5,6 | Half Load to/from Full Load, Notes 4,9 | -300 | | 300 | mVpk |
| Recovery time, step load changes (T _{TLD}) | 4,5,6 | Half Load to/from Full Load, Note 4,9,10 | | | 200 | μs |
| Output response to step line changes (V _{TLN}) | | 18V to/from 40V I _{OUT} = 100% rated load, Notes 1,4,11 | -300 | | 300 | mVpk |
| Recovery Time, step line changes (T _{TLN}) | | 18V to/from 40V I _{OUT} = 100% rated load, Notes 1,4,10,11 | | | 200 | μs |
| Turn-on Overshoot (V _{OS}) LS2801R5S LS2802R5S LS2803R3S LS2805S LS2812S LS2815S LS2805D LS2812D LS2815D Turn-on Delay (T _{DLY}) | 4,5,6 | 10% Load, Full Load Notes 4,12 | | | 150 250 330 500 1000 1000 500 1000 1000 10 | mV ms |
| Capacitive Load (C _L) LS2801R5S LS2802R5S LS2803R3S LS2805S LS2812S LS2815S LS2805D LS2812D LS2815D | | I _{OUT} = 100% rated load No effect on DC performance Notes 1, 4, 7 Each output on duals | | | 2500 2500 2200 1000 180 120 500 90 60 | μF |

For Notes to Electrical Performance Characteristics, refer to page 6

Electrical Performance Characteristics (continued)

| Parameter | Group A Subgroup | Conditions -55°C ≤ T _C ≤ +85°C V _{IN} = 28V DC ± 5%, C _L = 0 unless otherwise specified | Limits | | | Unit |
|----------------|------------------|---|-----------------------|-----|-----|------|
| | | | Min | Nom | Max | |
| Line Rejection | 1 | I _{OUT} = 100% rated load DC to 50 kHz, Notes 1, 4 | 35 | 50 | | dB |
| Isolation | 1 | Input to Output or Any Pin to Case except Pin 3, test @ 500V _{DC} | 100 | | | MΩ |
| Device Weight | | | | | 80 | g |
| MTBF | | MIL-HDBK-217F2, SF, 35°C | 4.0 x 10 ⁶ | | | Hr |

Notes for Electrical Performance Characteristics Table

- Parameter is tested as part of design characterization or after design changes. Thereafter, parameter shall be guaranteed to the limits specified.
- Parameter verified during line and load regulation tests.
- Output load current must be distributed such that at least 20% of the total load current is being provided by one of the outputs.
- Load current split equally between outputs on dual output models.
- Cross regulation is measured with 20% rated load on output under test while changing the load on the other output from 20% to 80% of rated.
- Guaranteed for a D.C. to 20MHz bandwidth. Tested using a 20kHz to 10MHz bandwidth using the circuit on page 6.
- Capacitive load may be any value from 0 to the maximum limit without compromising dc performance. For a capacitive load in excess of the maximum limit, consult the factory.
- Overload power dissipation is defined as the device power dissipation with the load set such that V_{OUT} = 90% of nominal.
- Load step transition time ≤ 10μs.
- Recovery time is measured from the initiation of the transient to where V_{OUT} has returned to within ±1% of its steady state value.
- Line step transition time ≤ 100μs.
- Turn-on delay time from either a step application of input power or a logic low to a logic high transition on the inhibit pin (pin 4) to the point where V_{OUT} = 90% of nominal.
- For operation at temperatures between +85°C and 125°C, de-rate the maximum output power linearly from 100% to 75%.
- End of Life (EOL) is ±3%

Fig. 1 - Circuit for measuring Output Ripple Voltage

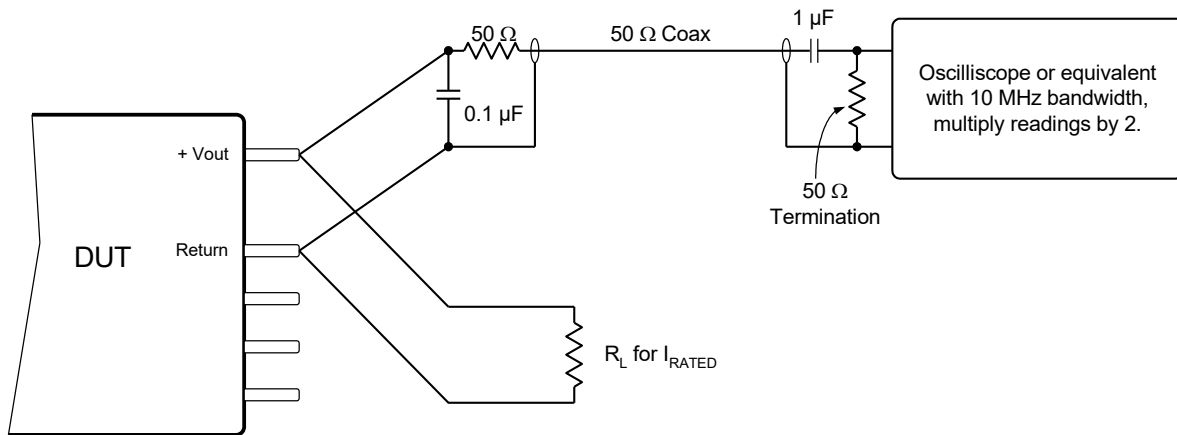

Radiation Performance Characteristics

| Test Inspection | Method | Min | Typ | Unit |
|---|---|-----|-----|-------------------------|
| Total Ionizing Dose (Gamma) | MIL-PRF-883, Method 1019.5 Operating bias applied during exposure, Full Rated Load, $V_{IN} = 28V$ | 100 | | kRads(Si) |
| Single Event Effects SEU, SEL, SEGR, SEB | Heavy Ions (LET) Operating bias applied during exposure, Full Rated Load, $V_{IN} = 28V$ Test lab: Cyclotron Institute Texas A & M University | 82 | | MeV•cm ² /mg |

IR HiRel currently does not have a DLA Land and Maritime certified Radiation Hardness Assurance Program.

LS Series Output Voltage Adjustment

Output of LS series can be adjusted to be greater or less than the nominal output voltage with an external resistor. However, the ranges of the output voltages are limited depending on the model as specified in Table 1 and 2. An approximate value of the resistor can be determined using the following formula.

For Single Output Model:

$$R_{adj} = \frac{A - (B * V_{out})}{(C * V_{out}) - D}$$

For Dual Output Model:

$$R_{adj} = \frac{A - (B * 2 * V_{out})}{(C * 2 * V_{out}) - D}$$

Where:

R_{adj} is the value of the external resistor in kilo-Ohms, R_{down} or R_{up} in Figure 1 or 2. Power rating of the resistor shall be ≥ 0.125W. Metal film resistor with temperature coefficient of ≤ ±50 ppm and tolerance of ≤ 1% is recommended. However, the final selection is dependent on specific design requirements.

V_{ovp} is the output voltage in volts.

A, B, C and D are unique constants depending on every model as shown in Table 1 for single output models and Table 2 for dual output models.

Table 1: Single Output Voltage Ranges and Constants

| Model | Output Voltage Range (V) (1) | A | B | C | D |
|-----------|------------------------------|--------|-------|------|-------|
| LS2801R5S | 1.500 to 1.600 | 69.65 | 32.39 | 8.75 | 13.13 |
| | 1.400 to 1.500 | 56.85 | 40.47 | 7.14 | 10.72 |
| LS2802R5S | 2.500 to 2.750 | 48.42 | 13.04 | 3.52 | 8.81 |
| | 2.250 to 2.500 | 39.52 | 21.19 | 2.88 | 7.19 |
| LS2803R3S | 3.300 to 3.630 | 43.48 | 9.25 | 2.50 | 8.25 |
| | 2.970 to 3.300 | 35.48 | 16.18 | 2.04 | 6.73 |
| LS2805S | 5.000 to 5.500 | 119.48 | 20.00 | 2.27 | 11.36 |
| | 4.500 to 5.000 | 97.52 | 29.31 | 1.85 | 9.27 |
| LS2812S | 12.000 to 13.200 | 295.22 | 19.98 | 2.27 | 27.24 |
| | 10.800 to 12.000 | 241.01 | 53.31 | 1.85 | 22.24 |
| LS2815S | 15.000 to 16.500 | 370.61 | 19.98 | 2.27 | 34.05 |
| | 13.500 to 15.000 | 302.55 | 63.61 | 1.85 | 27.80 |

Table 2: Dual Output Voltage Ranges and Constants

| Model | Voltage Range of Each Output ($\pm V_{out}$) (1) | A | B | C | D |
|---------|--|--------|-------|------|-------|
| LS2805D | ± 5.000 to ± 5.500 | 196.91 | 17.12 | 1.71 | 17.12 |
| | ± 4.500 to ± 5.000 | 160.74 | 31.11 | 1.40 | 13.97 |
| LS2812D | ± 12.000 to ± 13.200 | 475.43 | 17.05 | 1.71 | 40.92 |
| | ± 10.800 to ± 12.000 | 388.10 | 58.04 | 1.39 | 33.41 |
| LS2815D | ± 15.000 to ± 16.500 | 594.31 | 17.03 | 1.70 | 51.09 |
| | ± 13.500 to ± 15.000 | 485.10 | 69.47 | 1.39 | 41.70 |

Note:

(1). Also the minimum and maximum adjustment limits of the output voltage.

Placement of Radj

An external resistor must be added in order to trim the output voltage of an LS converter. The placement of an Radj resistor (Rdown or Rup) must be as shown in Figure 1 for single output models and as per Figure 2 for dual output models. Please note that the connections are made to the specific pins. Rup is placed across Out Return and Out Adj pins for output voltage greater than nominal output. Similar connections apply for the dual output models.

Figure 1: Radj Placement for Single Output Model

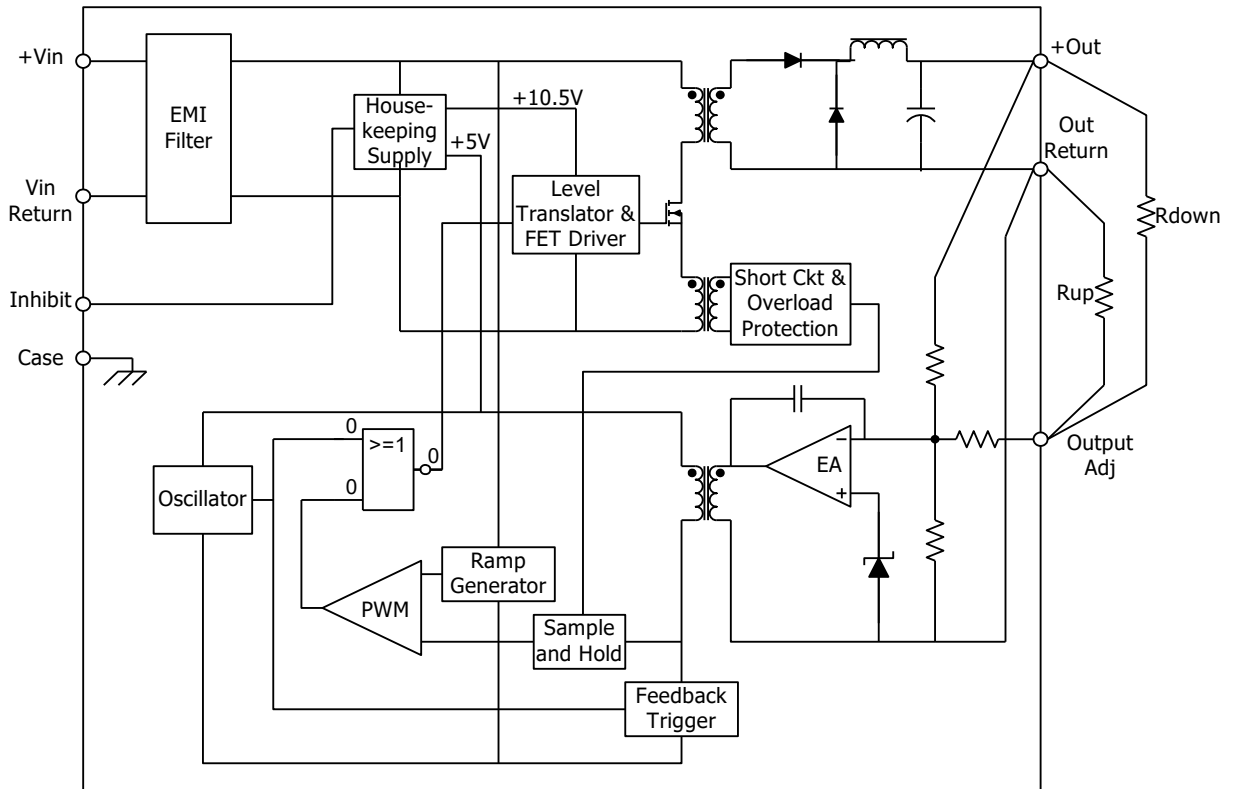
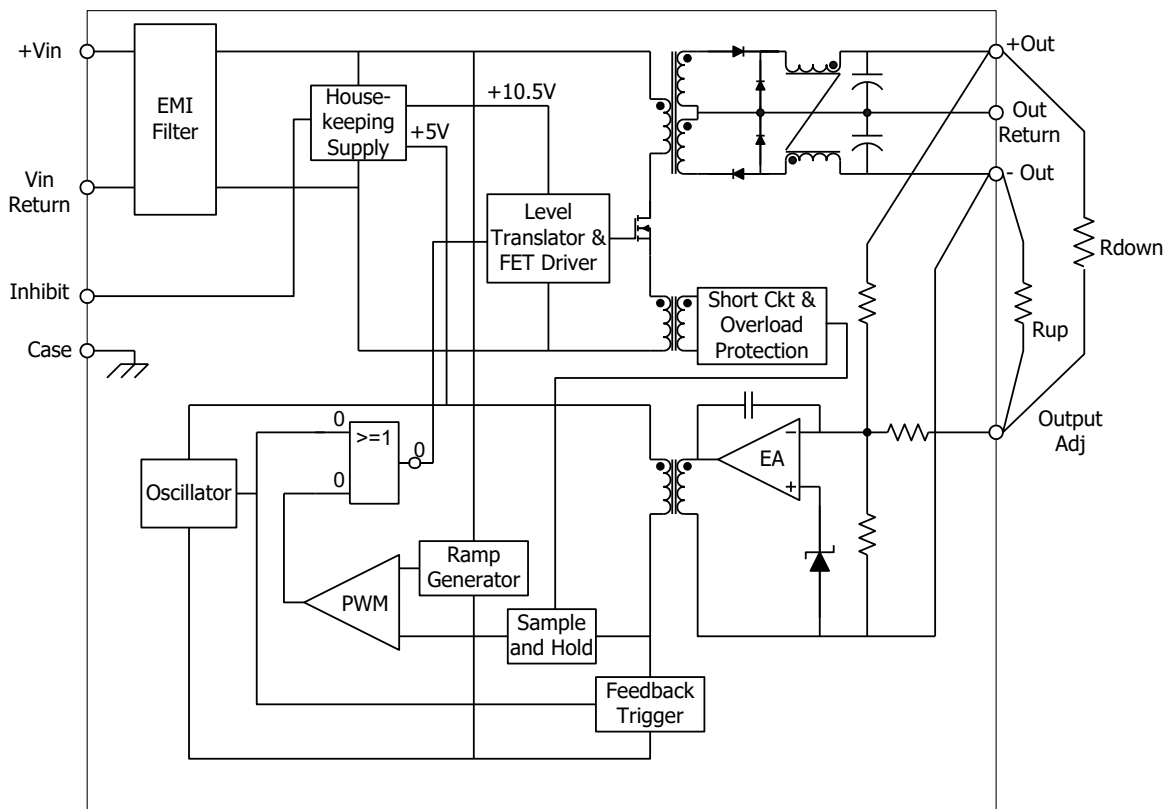
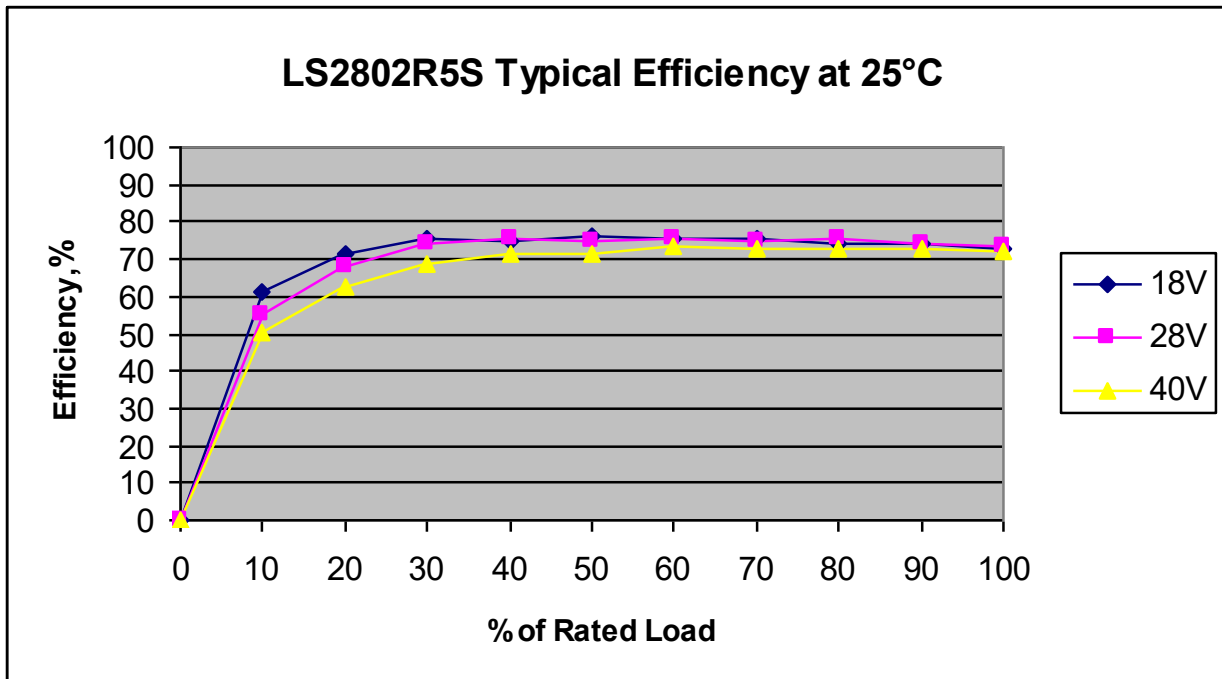
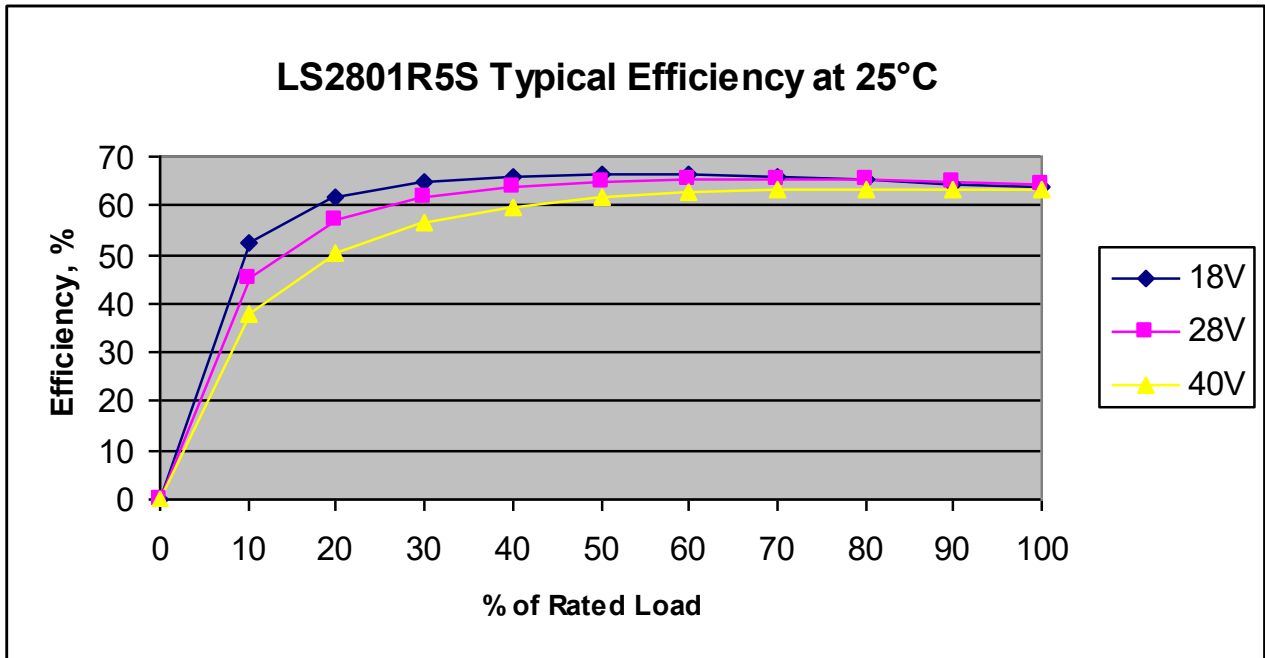
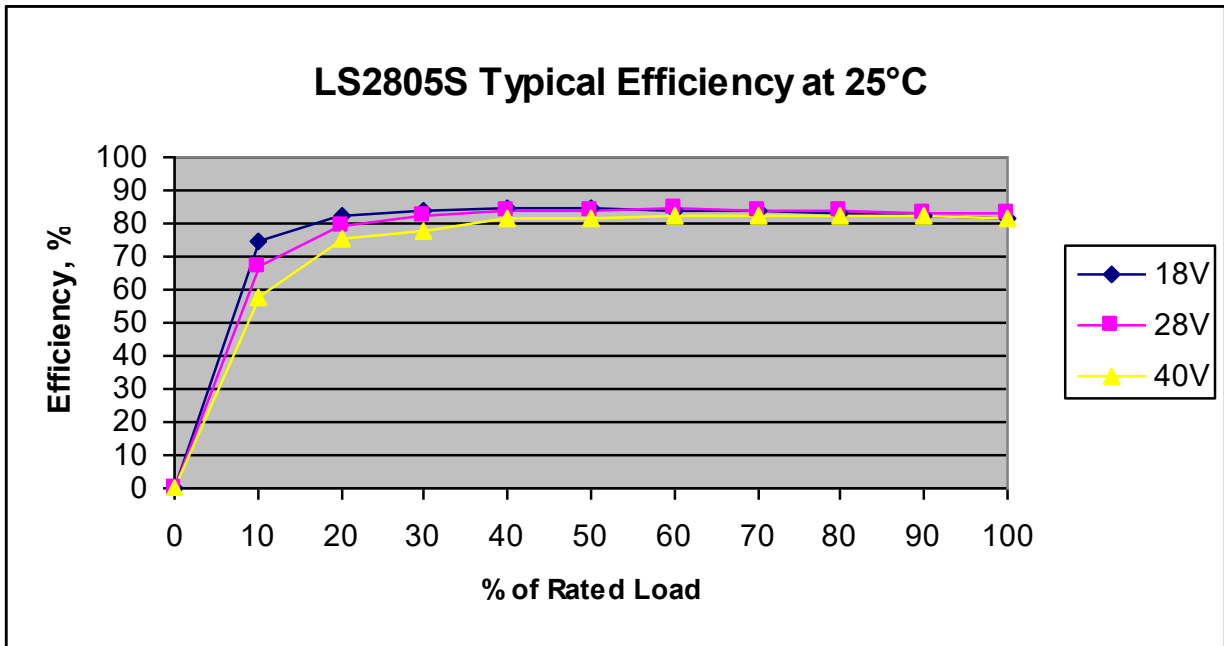
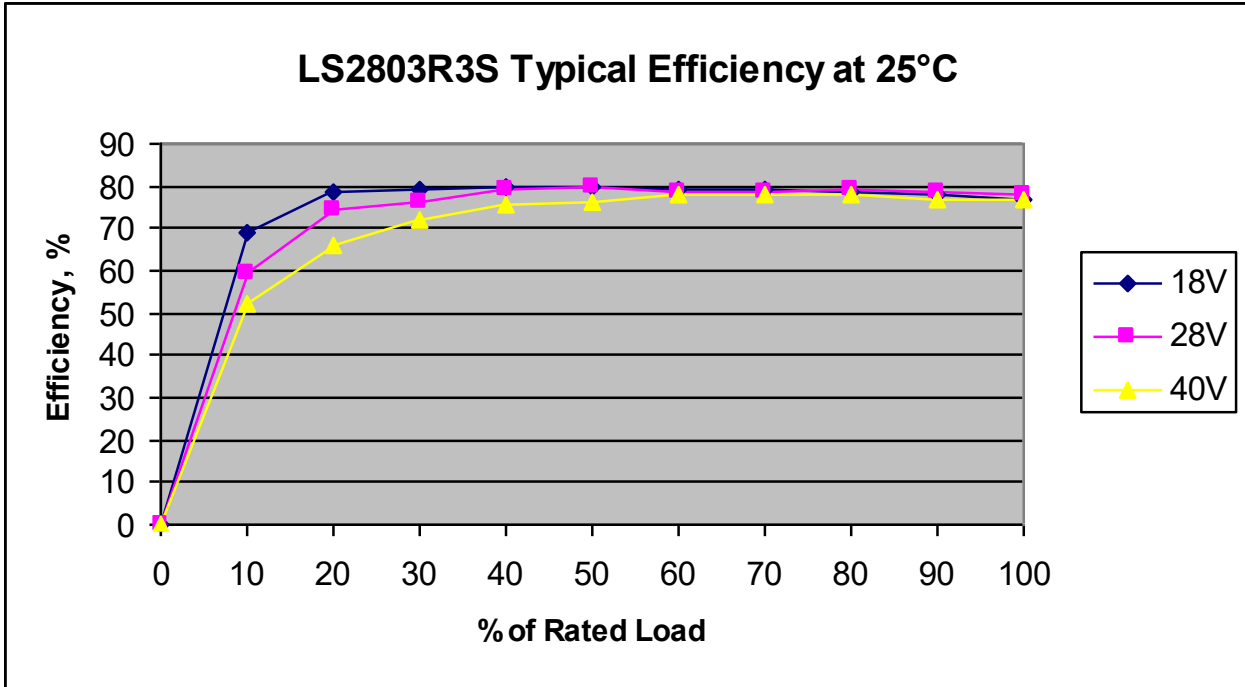

Figure 2: Radj Placement for Dual Output Model







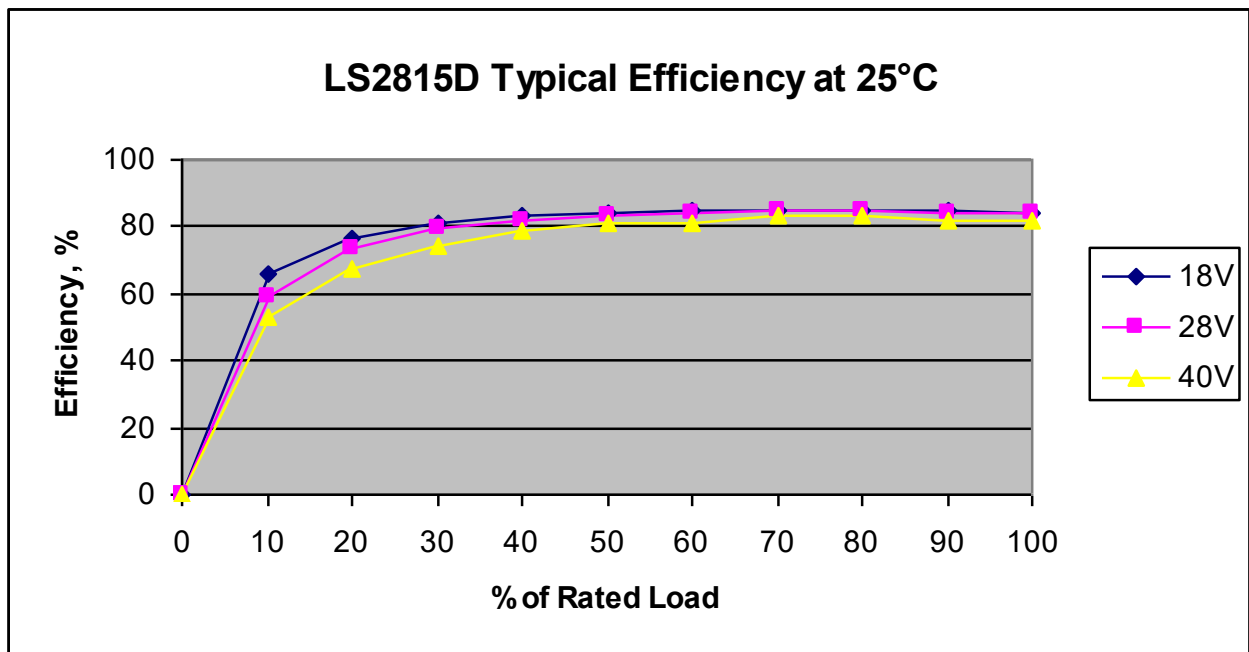
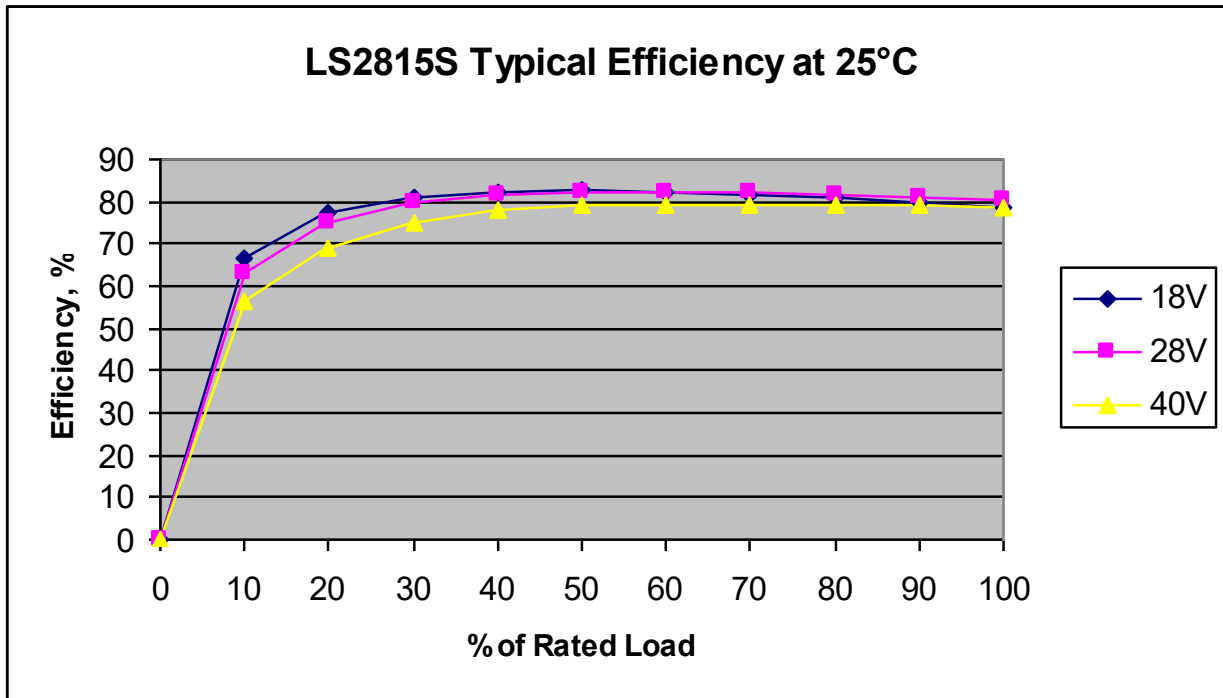

Figure 4: Block Diagram: Single Output Model

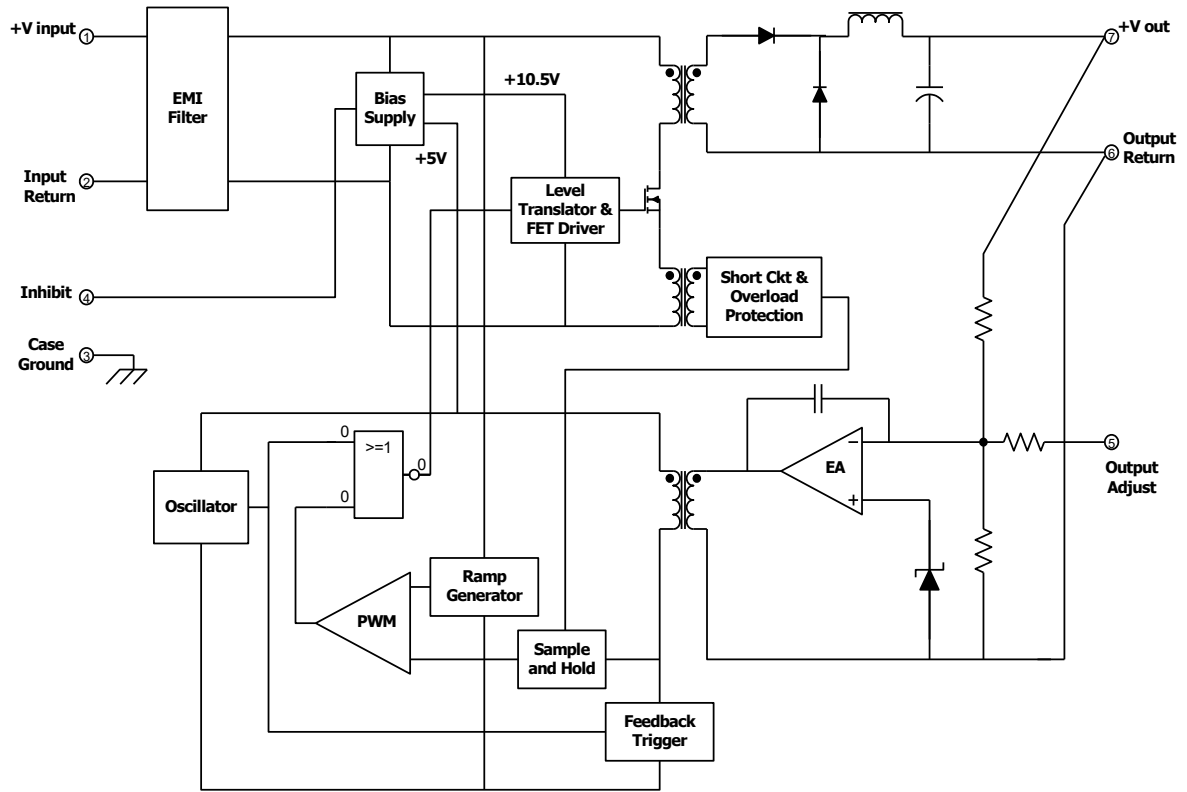
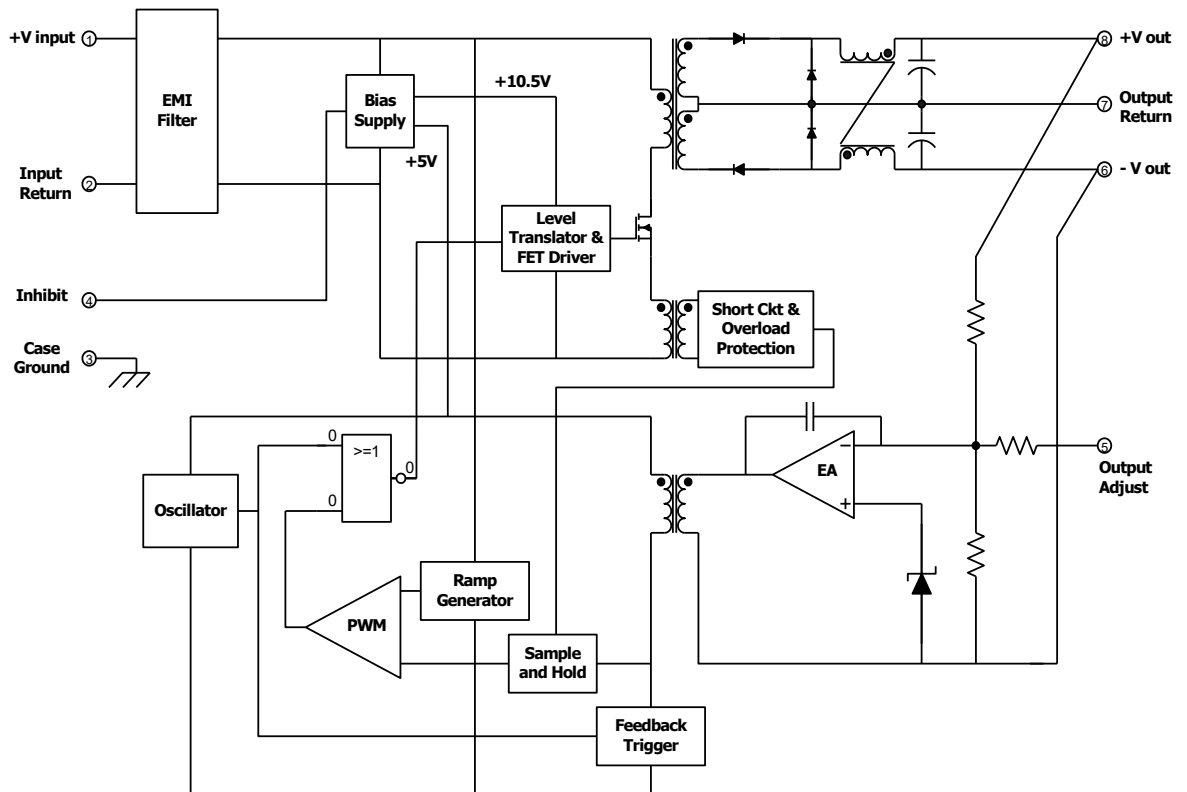

Figure 5: Block Diagram: Dual Output Model



Device Screening

| Part Number Designator | | /EM ① | /CK ② | 5962-xxxxxxxKyy ③ |
|-------------------------------|----------------------------------|------------------|----------------------------------|----------------------------------|
| Compliance Level | MIL-PRF-38534 | — | K level compliant | Class K SMD |
| Certification Mark | | — | CK | QML |
| Screening Requirement | MIL-STD-883 Method | — | — | — |
| Temperature Range | — | Room Temperature | -55°C to +85°C | -55°C to +85°C |
| Element Evaluation | MIL-PRF-38534 | N/A | Class K | Class K |
| Non-Destructive Bond Pull | 2023 | N/A | Yes | Yes |
| Internal Visual | 2017 | IR Defined | Yes | Yes |
| Temperature Cycle | 1010 | N/A | Cond C | Cond C |
| Constant Acceleration | 2001, Y1 Axis | N/A | 3000 Gs | 3000 Gs |
| PIND | 2020 | N/A | Cond A | Cond A |
| Burn-In | 1015 | N/A | 320 hrs @ 125°C (2 x 160 hrs) | 320 hrs @ 125°C (2 x 160 hrs) |
| Final Electrical (Group A) | MIL-PRF-38534 & Specification | Room Temperature | -55°C, +25°C, +85°C | -55°C, +25°C, +85°C |
| PDA | MIL-PRF-38534 | N/A | 2% | 2% |
| Seal, Fine and Gross | 1014 | N/A | Cond CH | Cond CH |
| Radiographic | 2012 | N/A | Yes | Yes |
| External Visual | 2009 | IR Defined | Yes | Yes |

Notes:

- ① **"EM" grade** parts are strictly intended to permit the customer to determine the electrical functionality of the device in the customer's application in ambient conditions. The use of EM devices in production applications presents an unquantifiable risk of failure and IR HiRel disclaims all responsibility for such failure.
- ② **"CK" grade** is the flight model (FM) compliant to K Level screening as defined in the DLA Land and Maritime MIL-PRF-38534 requirements, but is not necessarily a DLA Land and Maritime qualified SMD per MIL-PRF-38534. The governing document for this part number designator is the IR HiRel datasheet (this document). Radiation rating as stated in the "Radiation Performance Characteristics" section, is verified by analysis and test per IR HiRel internal procedure. The part is marked with the IR base part number and the "CK" certification mark.
- ③ **"Class K SMD" grade** has a DLA qualified SMD per DLA MIL-PRF-38534 Class K which is the governing document for this part. The part is marked with the IR base part number, the SMD part number and the "QML" certification mark.

Part Numbering

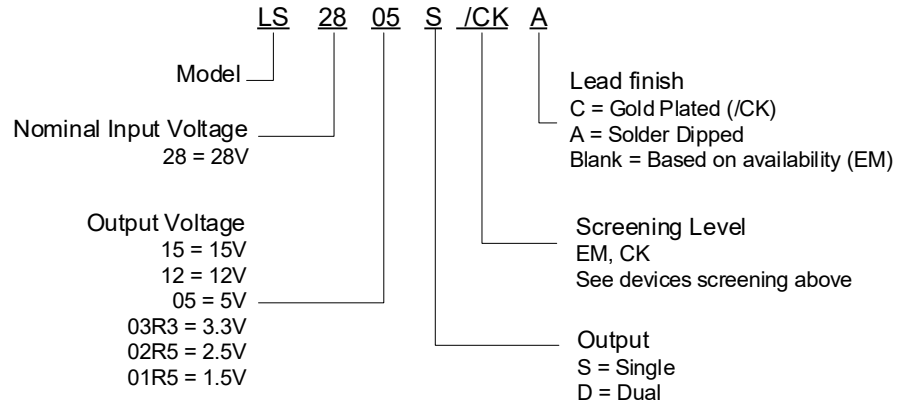

Orderable Part Numbers and DLA SMD Numbers

If a DLA SMD is available as listed in the table below, such model shall be ordered using the DLA SMD number. Otherwise the model shall be ordered using the part number nomenclature.

| Reference IR Base Model | Orderable Part Number | Lead finish |
|-------------------------|------------------------|---------------|
| LS2801R5S/CKA | 5962-0523801KXA | Solder Dipped |
| LS2801R5S/CKC | 5962-0523801KXC | Gold Plated |
| LS2803R3S/CKA | 5962-0523901KXA | Solder Dipped |
| LS2803R3S/CKC | 5962-0523901KXC | Gold Plated |
| LS2805S/CKA | 5962-0524001KXA | Solder Dipped |
| LS2805S/CKC | 5962-0524001KXC | Gold Plated |
| LS2812S/CKA | 5962-0624101KXA | Solder Dipped |
| LS2812S/CKC | 5962-0624101KXC | Gold Plated |
| LS2815S/CKA | 5962-0624201KXA | Solder Dipped |
| LS2815S/CKC | 5962-0624201KXC | Gold Plated |
| LS2805D/CKA | 5962-1022401KXA | Solder Dipped |
| LS2805D/CKC | 5962-1022401KXC | Gold Plated |
| LS2812D/CKA | 5962-0524101KXA | Solder Dipped |
| LS2812D/CKC | 5962-0524101KXC | Gold Plated |
| LS2815D/CKA | 5962-0524201KXA | Solder Dipped |
| LS2815D/CKC | 5962-0524201KXC | Gold Plated |