

**HYBRID-HIGH RELIABILITY
RADIATION HARDENED
DC-DC CONVERTER**

120W, Single Output

Description

The GHP2815S is a low voltage 15V/8A single output DC-DC converter. It is specifically designed in response to the need for moderate power, high efficiency and tight regulation required by modern day space design applications. This radiation hardened, high reliability converter is designed for extended operation in hostile environments. Its small size and low weight makes the GHP2815S ideal for applications such as geostationary earth orbit satellites and deep space probes. It exhibits a high tolerance to total ionizing dose, single event effects and environmental stresses such as temperature extremes, mechanical shock, and vibration. All components are fully de-rated to meet the requirements of MIL-STD-975, MIL-STD-1547 and GSFC PPL-21 Appendix B.

The design incorporates a fixed frequency topology with magnetic feedback. Incorporation of many functional features including external inhibit, output remote sensing, under-voltage lockout and synchronization makes this device suitable for today's space design applications.

The converter is enclosed in a hermetically sealed package with the overall dimensions of 3.50"L x 2.50"W x 0.475"H including the I/O pins and mounting tabs. The base material is aluminum-silicon-carbide. The lid material is Kovar. The I/O pins are rugged ceramic feed-through copper core Alloy 52. The lid is seam sealed using parallel seam welding. A complete GHP2815S converter weighs 110 grams maximum.

Manufactured in a facility fully qualified to MIL-PRF-38534, these converters are fabricated utilizing DLA qualified processes. For available screening options, refer to device screening table in the data sheet.

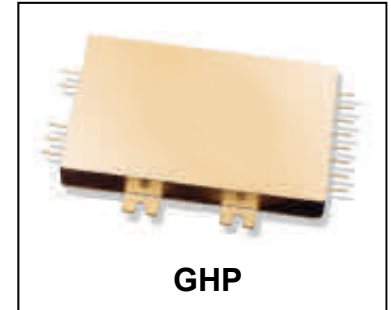

Features

- Total Ionizing Dose > 100 kRads(Si)
- SEE Hardened to LET up to 82 MeV.cm²/mg
- Low Weight < 110 grams
- Magnetically Coupled Feedback
- 18V to 40V DC Input Range
- Up to 120W Output Power
- High Efficiency - to 87%
- -55°C to +85°C Operating Temperature Range
- 100MΩ @ 500VDC Isolation
- Under-Voltage Lockout
- Short Circuit and Overload Protection
- Output Voltage Adjust
- Synchronization Input and Output
- Remote Sense
- External Inhibit

Applications

- Deep Space Satellites / Probes
- Strategic Weapons and Communication System
- Geostationary Earth Orbit Satellites (GEO)

Specifications

Absolute Maximum Ratings		Recommended Operating Conditions	
Input Voltage	-0.5V _{dc} to +50V _{DC}	Input Voltage range	+18V _{DC} to +40V _{DC}
Output power	Internally limited	Output power	0 to Max. Rated
Lead Temperature	+300°C for 10 seconds	Operating temperature	-55°C to +85°C
Operating temperature	-55°C to +125°C	Operating temperature ¹	-55°C to +70°C
Storage temperature	-55°C to +125°C		

¹ Meets de-rating per MIL-STD-975

Electrical Performance Characteristics

Parameter	Group A Subgroup	Conditions -55°C ≤ T _C ≤ +85°C V _{IN} = 28V DC ± 5%, C _L = 0 unless otherwise specified	Limits		Unit
			Min	Max	
Input voltage (V _{IN})			18	40	V
Output voltage (V _{OUT})	1 2, 3	I _{OUT} = 100% rated load	14.94 14.80	15.06 15.20	V
Output voltage with open sense (V _{OSO})	1	I _{OUT} = 0 Remote sense connections open	15.4	15.6	Vdc
Output voltage adjust (V _{ADJ})	1	I _{OUT} = 0A Output adjust pin (pin 12) shorted to output return (pins 9 & 10)	16.4	16.6	Vdc
Output power (P _{OUT})	1, 2, 3	V _{IN} = 18, 28, 40 Volts, Note 2	0	120	W
Output current (I _{OUT})	1, 2, 3	V _{IN} = 18, 28, 40 Volts, Note 2		8.0	A
Line regulation (VR _{LINE})	1, 2, 3	V _{IN} = 18, 28, 40 Volts I _{OUT} = 0, 50%, 100% rated	-10	+10	mV
Load regulation (VR _{LOAD})	1, 2, 3	I _{OUT} = 0, 50%, 100% rated V _{IN} = 18, 28, 40 Volts	-75	+75	mV
Input current (I _{IN})	1, 2, 3	I _{OUT} = 0, pin 3 open Pin 3 shorted to Pin 2		100 5.0	mA
Switching frequency (F _S)	1, 2, 3	Sync. Input (pin 4) open	450	550	kHz
Sync frequency range (F _{SYNC})	1, 2, 3	Ext. Clock on Sync. Input (pin 4)	450	600	kHz
Output ripple voltage (V _{RIP})	1, 2, 3	V _{IN} = 18, 28, 40 V I _{OUT} = 100% rated load, Note 3	0	50	mVp-p
Efficiency (E _{FF})	1 2,3	I _{OUT} = 100% rated load	84 82		%
Current limit point (I _{LM})	1, 2, 3	V _{OUT} = 90% of Nominal	8.4	10.8	A
Power Dissipation load fault (P _D)	1, 2, 3	Overload, Note 9		35	W
Power dissipation load Fault (P _D)	1, 2, 3	Short Circuit		35	W

For Notes to Electrical Performance Characteristics, refer to page 3

Electrical Performance Characteristics (continued)

Parameter	Group A Subgroup	Conditions -55°C ≤ T _C ≤ +85°C V _{IN} = 28V DC ± 5%, C _L = 0 unless otherwise specified	Limits		Unit
			Min	Max	
Output response to step load changes (V _{TLD})	4, 5, 6	Half Load to/from Full Load, Note 5	-750	+750	mVpk
Recovery time, step load changes (T _{TLD})	4, 5, 6	Half Load to/from Full Load, Notes 5, 6		200	μs
Output response to step line changes (V _{TLN})	4, 5, 6	Input Step 18V to/from 40V I _{OUT} = 100% rated load, Notes 1, 7	-500	+500	mVpk
Recovery time, step line changes (T _{TLN})	4, 5, 6	Input Step 18V to/from 40V I _{OUT} = 100% rated load, Notes 1, 6, 7		200	μs
Turn-on overshoot (V _{OS})	4, 5, 6	No Load, 100% Load	0	500	mV
Turn-on delay (T _{DLY})	4, 5, 6	No Load, 100% Load, Note 8	1.0	5.0	ms
Capacitive load (C _L)	1	I _{OUT} = 100% rated load No effect on DC performance, Notes 1, 4		1000	μF
Isolation (I _{SO})	1	Input to Output or Any Pin to Case except pin 13, test @ 500 Vdc	100		MΩ

Notes:

1. Parameter is tested as part of design characterization or after design changes. Thereafter, parameter shall be guaranteed to the limits specified.
2. Parameter verified during line and load regulation tests.
3. Guaranteed for a DC to 20MHz bandwidth. Tested using a 20kHz to 10MHz bandwidth.
4. Capacitive load may be any value from 0 to the maximum limit without compromising DC performance.
5. Load step transition time ≥ 10μs
6. Recovery time is measured from the initiation of the transient to where V_{OUT} has returned to within ±1% of its steady state value.
7. Line step transition time ≥ 100μs.
8. Turn-on delay time from either a step application of input power or a logical low to high transition on the inhibit pin (pin 3) while power is applied to the input to the point where V_{OUT} = 90% of nominal.
9. Overload Power Dissipation is defined as the device power dissipation with the load set such that V_{OUT} = 90% of nominal.

Radiation Performance Characteristics

Test	Conditions	Min	Typ	Unit
Total Ionizing Dose (Gamma)	MIL-STD-883, Method 1019 Operating bias applied during exposure, Full Rated Load, V _{IN} = 28V	100		kRads (Si)
Single Event Effects SEU, SEL, SEGR, SEB	Heavy ions (LET) Operating bias applied during exposure, Full Rated Load, V _{IN} = 28V	82		MeV.cm ² /mg

Fig 1. Block Diagram - Single Output

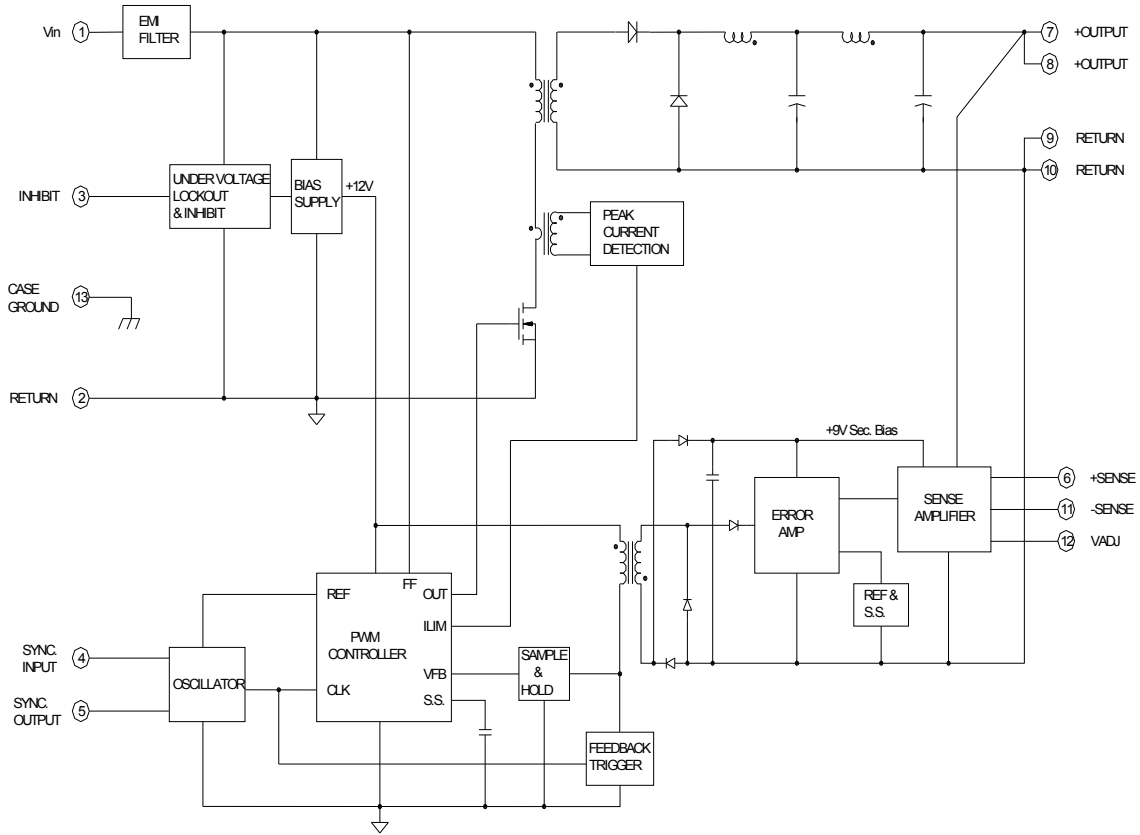

Mechanical Outline

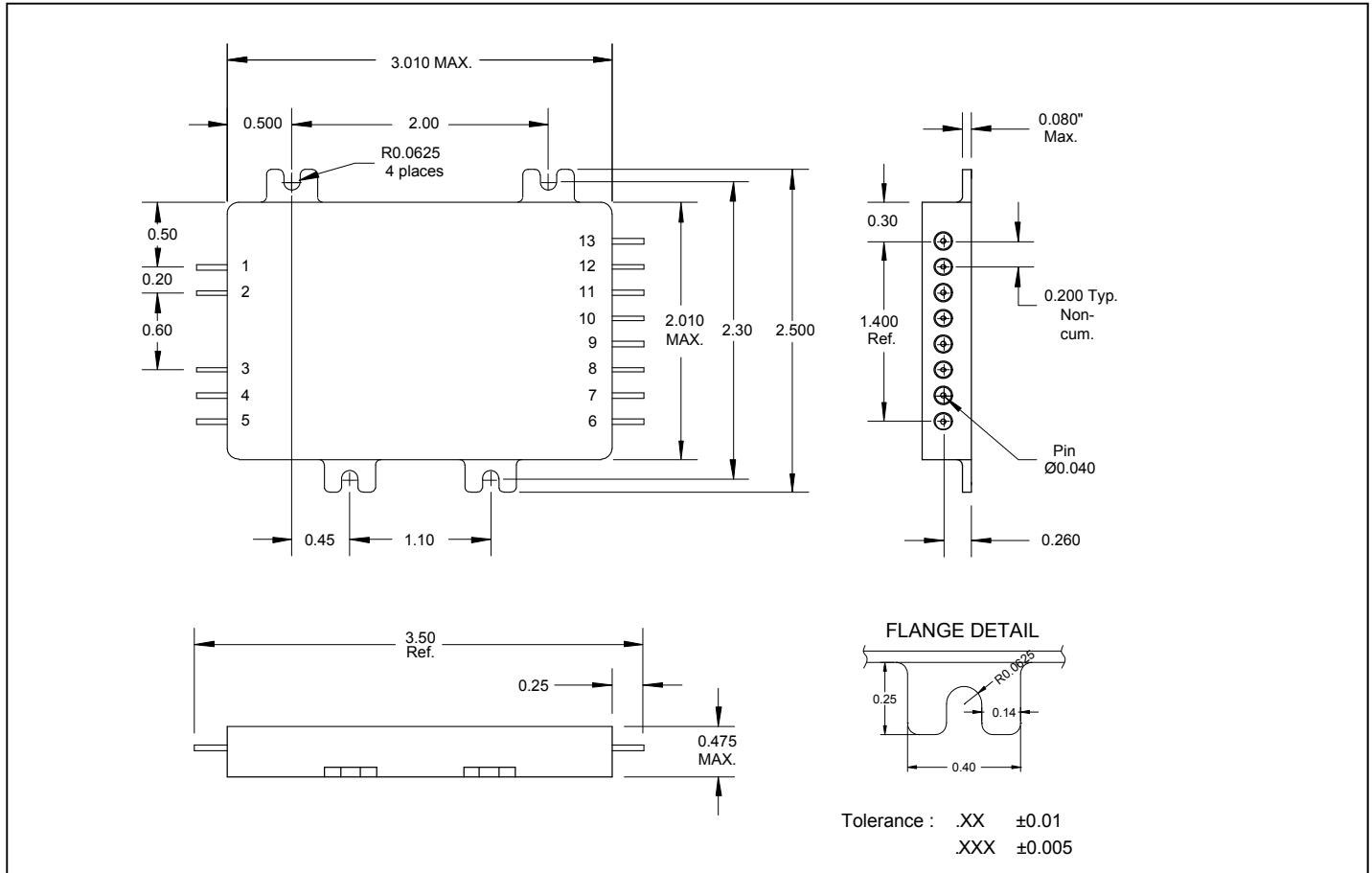

Pin Designation

Pin #	Designation	Pin #	Designation
1	Vin	8	+ OUTPUT
2	RETURN	9	RETURN
3	INHIBIT	10	RETURN
4	SYNC. INPUT	11	-SENSE
5	SYNC. OUTPUT	12	VADJ
6	+ SENSE	13	CASE GROUND
7	+ OUTPUT		

Device Screening

Requirement	MIL-STD-883 Method	No Suffix ②	CK ②	EM ③
Temperature Range	—	-55°C to +85°C	-55°C to +85°C	-55°C to +85°C
Element Evaluation	MIL-PRF-38534	Class K	Class K	N/A
Non-Destructive Bond Pull	2023	Yes	Yes	N/A
Internal Visual	2017	Yes	Yes	①
Temperature Cycle	1010	Cond C	Cond C	Cond C
Constant Acceleration	2001, Y1 Axis	3000 Gs	3000 Gs	3000 Gs
PIND	2020	Cond A	Cond A	N/A
Burn-In	1015	320 hrs @ 125°C (2 x 160 hrs)	320 hrs @ 125°C (2 x 160 hrs)	48 hrs @ 125°C
Final Electrical (Group A)	MIL-PRF-38534 & Specification	-55°C, +25°C, +85°C	-55°C, +25°C, +85°C	-55°C, +25°C, +85°C
PDA	MIL-PRF-38534	2%	2%	N/A
Seal, Fine and Gross	1014	Cond A, C	Cond A, C	Cond A
Radiographic	2012	Yes	Yes	N/A
External Visual	2009	Yes	Yes	①

Notes:

- ① Best commercial practice.
- ② CK is a DLA Land and Maritime (formerly DSCC) part marking used to designate a Class K compliant hybrid. The CK marking does not indicate the hybrid is radiation certified. No Suffix is a radiation rated device but not available as a DLA Land and Maritime qualified SMD per MIL-PRF-38534.
- ③ Any Engineering Model (EM) build with the “EM” Suffix shall only be form, fit and functional equivalent to its Flight Model (FM) counterpart, and it may not meet the radiation performance. The EM Model shall not be expected comply with MIL-PRF-38534 flight quality/workmanship standards, and configuration control. An EM build may use electrical equivalent commercial grade components. IR HiRel will provide a list of non-compliance items upon request.

Part Numbering

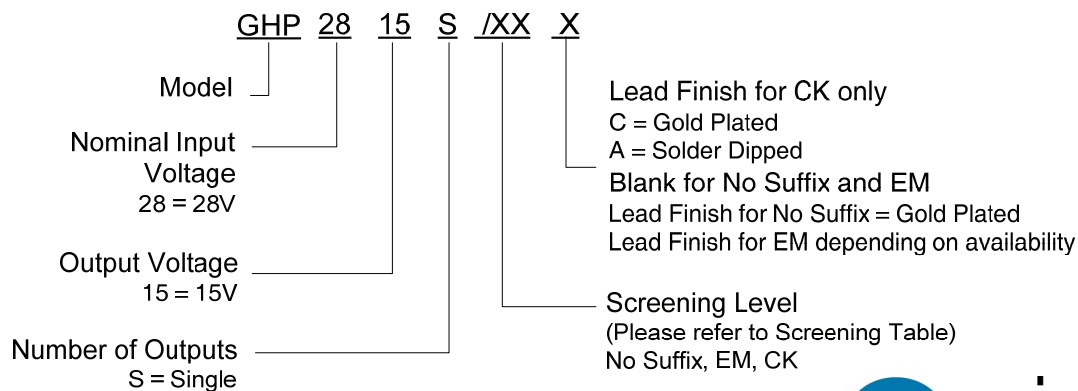

one source. one solution.®

www.micross.com

Americas: 1.855.426.6766

EMEA & APAC: +44 (0) 1603.788967

China: +85 21.5459.1970

India: +91 7760.990.545

Micross Components reserves the right to change products or specifications without notice.