

HYBRID-HIGH RELIABILITY RADIATION HARDENED DC-DC CONVERTER

28V Input, Single/Dual Output

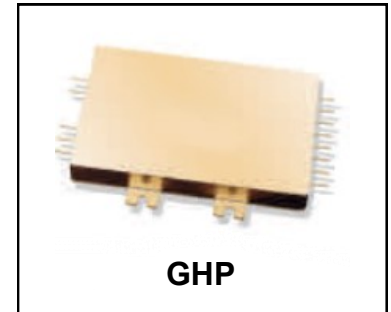

Description

The GHP-Series of DC-DC converters are radiation hardened, high reliability converters specifically designed in response to the need for moderate power, high efficiency and well regulated output required by the modern day space design applications. Their small size and low weight make them ideal for applications such as geostationary earth orbit satellites and deep space probes. They exhibit a high tolerance to total ionizing dose, single event effects and environmental stresses such as temperature extremes, mechanical shock, and vibration.

The converters incorporate a fixed frequency single ended forward topology with magnetic feedback and an internal EMI filter that utilizes multilayer ceramic capacitors that are subjected to extensive lot screening for optimum reliability. By using two stage filtering these converters produce low input and output noise. External inhibit and synchronization input and output allow these converters to be easily incorporated into larger power systems. They are enclosed in a hermetic 3" x 2" x 0.475" package constructed of an Aluminum-Silicon-Carbide (AlSiC) base and an Alloy 48 ring frame and they weigh less than 110 grams. The package utilizes rugged ceramic feed-through copper core pins and is sealed using parallel seam welding.

Manufactured in a facility fully qualified to MIL-PRF-38534, these converters are fabricated utilizing DLA Land and Maritime qualified processes. For available screening options, refer to device screening table in the data sheet.

Non-flight versions of the GHP-Series converters are available for system development purposes. Variations in electrical specifications and screening to meet custom requirements can be accommodated.

Features

- Total Dose > 100 kRads(Si)
- SEE Hardened to LET up to 82 MeV.cm²/mg
- Low Weight < 110 grams
- Low Input & Output Noise
- Magnetically Coupled Feedback
- 18V to 40V DC Input Range
- Up to 120W Output Power
- Single and Dual Output Models Include 5, 12, 15 and ±5, ±12 and ±15V
- High Efficiency - to 87%
- -55°C to +125°C Operating Temperature Range
- 100MΩ @ 500VDC Isolation
- Under-Voltage Lockout
- Short Circuit and Overload Protection
- Adjustable Output with an External Resistor
- Remote Sense on Single Output Models
- Synchronization Input and Output
- External Inhibit
- > 3.3 Million Hours MTBF

Applications

- Geostationary Earth Orbit Satellites (GEO)
- Deep Space Satellites / Probes
- Strategic Weapons and Communication System

Specifications

Absolute Maximum Ratings		Recommended Operating Conditions	
Input Voltage	-0.5V _{DC} to +50V _{DC}	Input Voltage	+18V _{DC} to +40V _{DC}
Output power	Internally limited	Output power	0 to Max. Rated
Lead Temperature	+300°C for 10 seconds	Operating temperature	-55°C to +85°C
Operating temperature	-55°C to +125°C	Operating temperature ¹	-55°C to +70°C
Storage temperature	-55°C to +125°C		

¹ Meets de-rating per MIL-STD-975

Electrical Performance Characteristics

Parameter	Group A Subgroup	Conditions -55°C ≤ T _C ≤ +85°C V _{IN} = 28V DC ± 5%, C _L = 0 unless otherwise specified	Limits			Unit
			Min	Nom	Max	
Input voltage (V _{IN})			18	28	40	V
Output voltage (V _{OUT})						
GHP2805S	1	I _{OUT} = 100% rated load Note 4	4.98	5.00	5.02	V
GHP2812S	1		11.95	12.00	12.05	
GHP2815S	1		14.94	15.00	15.06	
GHP2805D	1		±4.95	±5.00	±5.05	
GHP2812D	1		±11.95	±12.00	±12.05	
GHP2815D	1		±14.94	±15.00	±15.06	
GHP2805S	2,3	I _{OUT} = 100% rated load Note 4	4.93		5.07	
GHP2812S	2,3		11.84		12.16	
GHP2815S	2,3		14.80		15.20	
GHP2805D	2,3		±4.90		±5.10	
GHP2812D	2,3		±11.84		±12.16	
GHP2815D	2,3		±14.80		±15.20	
Output power (P _{OUT})						
GHP2805S	1,2,3	V _{IN} = 18, 28, 40 Volts, Note 2	0		100	W
GHP2812S			0		120	
GHP2815S			0		120	
GHP2805D			0		100	
GHP2812D			0		100	
GHP2815D			0		100	
Output current (I _{OUT})						
GHP2805S	1,2,3	V _{IN} = 18, 28, 40 Volts, Note 2 Either Output, Note 3 Either Output, Note 3 Either Output, Note 3	0		20	A
GHP2812S			0		10	
GHP2815S			0		8.0	
GHP2805D			3.2		16	
GHP2812D			1.33		6.67	
GHP2815D			1.07		5.33	
Line regulation (VR _{LINE})	1,2,3	V _{IN} = 18, 28, 40 Volts I _{OUT} = 0, 50%, 100% rated, Note 4	-10		10	mV
Load regulation (VR _{LOAD})	1,2,3	I _{OUT} = 0, 50%, 100% rated, Note 4 V _{IN} = 18, 28, 40 Volts	-0.5		0.5	%

For Notes to Electrical Performance Characteristics, refer to page 5

Electrical Performance Characteristics (continued)

Parameter	Group A Subgroup	Conditions -55°C ≤ T _C ≤ +85°C V _{IN} = 28V DC ± 5%, C _L = 0 unless otherwise specified	Limits			Unit
			Min	Nom	Max	
Cross regulation (V _R CROSS) GHP2805D GHP2812D GHP2815D	1,2,3	Duals only, Note 5 V _{IN} = 18, 28, 40 Volts	-5.0 -3.0 -3.0		5.0 3.0 3.0	%
Total regulation (Line, Load, and Temperature)	1,2,3	V _{IN} = 18, 28, 40 Volts I _{OUT} = 0, 50%, 100% rated, Dual Model is measured From +Output to -Output, Note 13	-2.0		2.0	%
Input current (I _{IN})	1,2,3	I _{OUT} = 0, Pin 3 open, Note 14 Pin 3 shorted to Pin 2		70 2.5	120 5.0	mA
Output ripple (V _{RIP}) GHP2805S GHP2812S GHP2815S GHP2805D GHP2812D GHP2815D	1,2,3	V _{IN} = 18, 28, 40 Volts I _{OUT} = 100% rated load Notes 4, 6		15 25 25 20 20 20	50 60 60 60 60 60	mVp-p
Input ripple current	1,2,3	I _{OUT} = 100% rated load			30	mArms
Switching frequency (F _S)	1,2,3	Sync. Input (Pin 4) open	450	500	550	kHz
Efficiency (E _{FF}) GHP2805S GHP2812S GHP2815S GHP2805D GHP2812D GHP2815D	1,2,3	I _{OUT} = 100% rated load Note 4	78 81 82 78 81 82	82 85 86 82 84 86		%
Inhibit Input Converter Off Sink current Converter On Sink current	1,2,3	Logic Low on Pin 3 Note 1 Logic High on Pin 3, Note 3 Note 1	-0.5 2.4		0.7 100 50 100	V μA V μA

For Notes to Electrical Performance Characteristics, refer to page 5

Electrical Performance Characteristics (continued)

Parameter	Group A Subgroup	Conditions -55°C ≤ T _C ≤ +85°C V _{IN} = 28V DC ± 5%, C _L = 0 unless otherwise specified	Limits			Unit
			Min	Nom	Max	
Synchronization Input frequency range pulse high level pulse low level pulse transition time pulse duty cycle		Ext. Clock on Sync. Input (Pin 4) Note 1	450 4.0 -0.5 40 20		600 10.0 0.5 80	kHz V V V/μs %
Current Limit Point Expressed as a percentage of full rated load current	1,2,3	V _{OUT} = 90% of Nominal, Note 4			145	%
Power dissipation, load fault (P _D)	1,2,3	Short Circuit, Overload, Note 8			35	W
Output response to step load changes (V _{TLD}) GHP2805S GHP2812S GHP2815S GHP2805D GHP2812D GHP2815D	4,5,6	Half Load to/from Full Load, Notes 4,9	-450 -600 -750 -450 -750 -750		450 600 750 450 750 750	mVpk
Recovery time, step load changes (T _{TLD})	4,5,6	Half Load to/from Full Load, Notes 4, 9,10			200	μs
Output response to step line changes (V _{TLN})		18V to/from 40V I _{OUT} = 100% rated load, Notes 1, 4,11	-150		150	mVpk
Recovery time, step line changes (T _{TLN})		18V to/from 40V I _{OUT} = 100% rated load, Notes 1,4,10,11			200	μs
Capacitive load (C _L) GHP2805S GHP2812S GHP2815S GHP2805D GHP2812D GHP2815D		I _{OUT} = 100% rated load No effect on DC performance Notes 1, 4, 7 Each output on duals			5000 1000 1000 1000 500 500	μF
Turn-on Response Overshoot (V _{OS}) Turn-on Delay (T _{DLY})	4,5,6	No Load, Full Load Notes 4,12	0.5		2.0 8.0	% ms
Line Rejection		I _{OUT} = 100% rated load DC to 50 kHz, Notes 1, 4	40			dB
Isolation	1	Input to Output or Any Pin to Case except Pin 6, test @ 500VDC	100			MΩ
Device Weight					110	g
MTBF		MIL-HDBK-217F2, SF, 35°C	3.3 x 10 ⁶			Hrs

For Notes to Electrical Performance Characteristics, refer to page 5

Notes: Electrical Performance Characteristics Table

1. Parameter is tested as part of design characterization or after design changes. Thereafter, parameter shall be guaranteed to the limits specified.
2. Parameter verified during line and load regulation tests.
3. Output load current must be distributed such that at least 20% of the total load current is being provided by one of the outputs.
4. Load current split equally between outputs on dual output models.
5. Cross regulation is measured with 20% rated load on output under test while changing the load on the other output from 20% to 80% of rated.
6. Guaranteed for a DC to 20 MHz bandwidth. Tested using a 20 kHz to 10 MHz bandwidth.
7. Capacitive load may be any value from 0 to the maximum limit without compromising dc performance. A capacitive load in excess of the maximum limit may interfere with the proper operation of the converter's overload protection, causing erratic behavior during turn-on.
8. Overload power dissipation is defined as the device power dissipation with the load set such that $V_{OUT} = 90\%$ of nominal.
9. Load step transition time $\geq 10 \mu\text{s}$.
10. Recovery time is measured from the initiation of the transient to where V_{OUT} has returned to within $\pm 1\%$ of its steady state value.
11. Line step transition time $\geq 100 \mu\text{s}$.
12. Turn-on delay time from either a step application of input power or a logic low to a logic high transition on the inhibit pin (pin 3) to the point where $V_{OUT} = 90\%$ of nominal.
13. Total regulation at EOL is $\pm 3\%$ maximum.
14. The input current is minimized with an output load of 300mW to 400mW. If a system design requires converter operation at or near zero load (e.g. a system standby mode), then it is recommended that a resistive preload of 300mW to 400mW will be added to converter's output (s). The small preload will reduce the converter's "no load" input current from approximately 70mA to approximately 30mA.

Radiation Performance Characteristics

Test	Conditions	Min	Typ	Unit
Total Ionizing Dose (Gamma)	MIL-STD-883, Method 1019 Operating bias applied during exposure Biased $V_{IN} = 28\text{V}$	100	150	kRads (Si)
Single Event Effects SEU, SEL, SEGR, SEB	Heavy ions (LET) Operating bias applied during exposure, Full Rated Load. $V_{IN} = 18\text{V}, 28\text{V}, 40\text{V}$ Test Lab: Texas A & M University	82		MeV.cm ² /mg

Fig 1. Block Diagram - Single Output

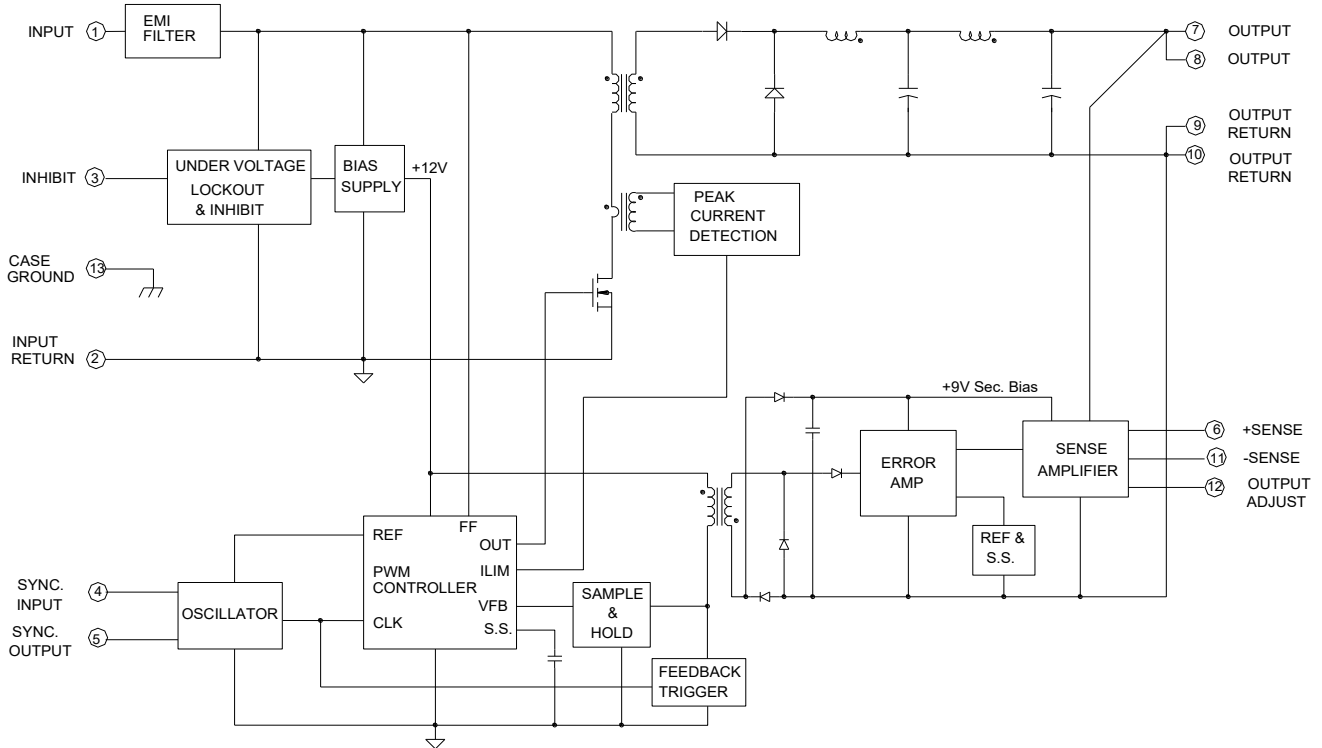
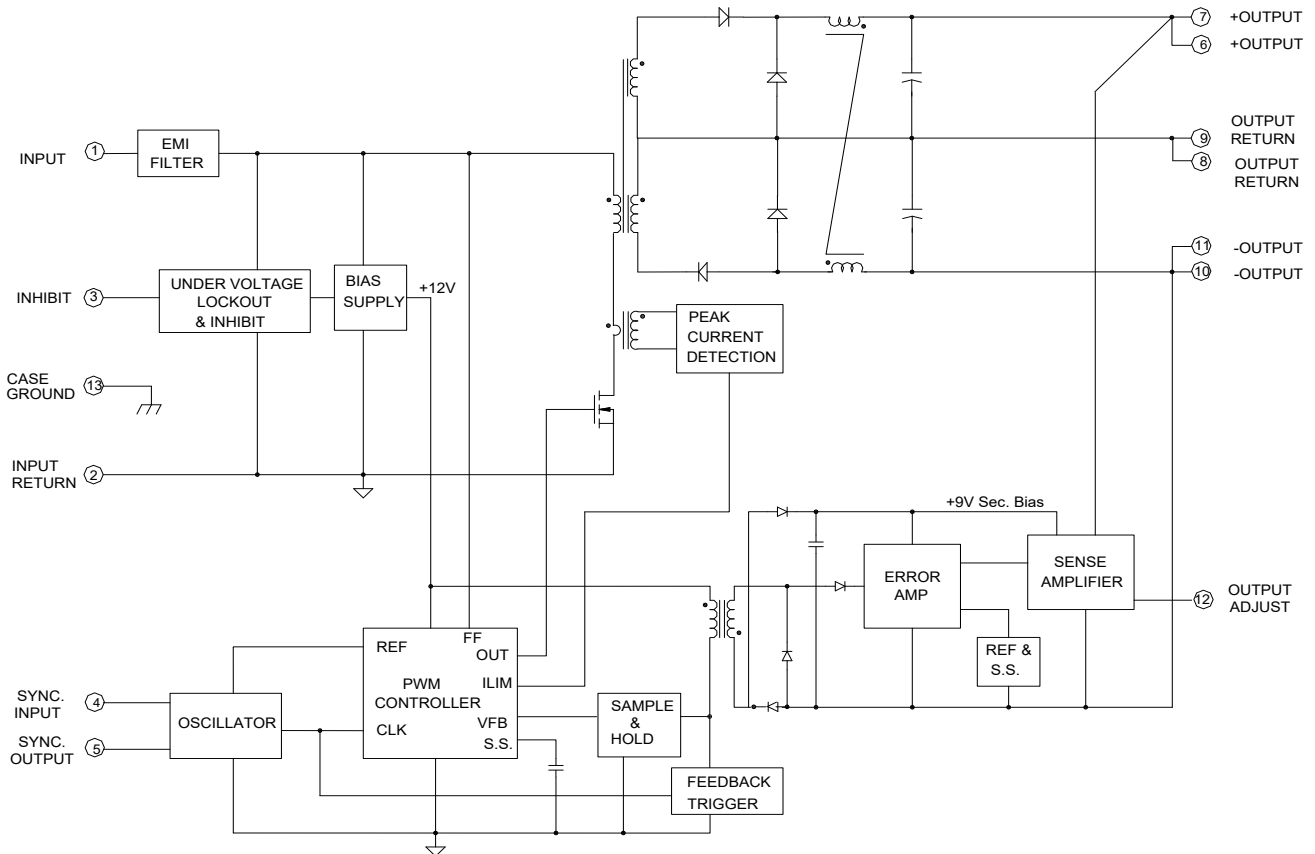

Fig 2. Block Diagram - Dual Output



Application Notes:

A) Attachment of the Converter

The following procedure is recommended for mounting the converter for optimum cooling and to circumvent any potential damage to the converter.

Ensure that flatness of the plate where GHP converter to be mounted is no greater than 0.003" per linear inch. It is recommended that a thermally conductive gasket is used to promote the thermal transfer and to fill any voids existing between the two surfaces. HiRel recommends Sil-Pad 2000 with the thickness of 0.010". The shape of the gasket should match the footprint of the converter including the mounting flanges. The gasket is available from IR HiRel. The GHP-Series converter requires either M3 or 4-40 size screws for attachment purposes.

The procedure for mounting the converter is as follows:

1. Check all mounting surfaces and remove foreign material, burrs, if any or anything that may interfere with the attachment of the converter.
2. Place the gasket on the surface reserved for the converter and line it up with the mounting holes.
3. Place the converter on the gasket and line both up with mounting holes.
4. Install screws using appropriate washers and tighten by hand (~ 4 in·oz) in the sequence shown below.

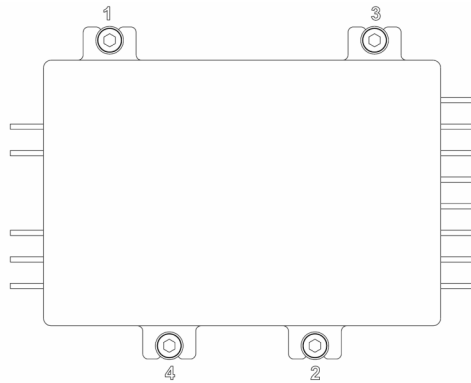

5. Tighten the screws with an appropriate torque driver. Torque the screws up to 6 in·lb in the sequence shown above.

B) Output Voltage Adjustment.

Single Output:

To adjust the output voltage of the single output models, a resistor (R_{ADJ}) is connected between the Adjust pin (Pin 12) and either the positive or negative remote sense pins, depending on whether the output voltage is to be adjusted higher or lower than the nominal set-point. This allows the outputs to be reliably adjusted by approximately +10% to -20% of the nominal output voltage. Refer to Fig. 3 and use equations provided to calculate the required resistance (R_{ADJ}).

Fig 3. Configuration for Adjusting Single Output Voltage

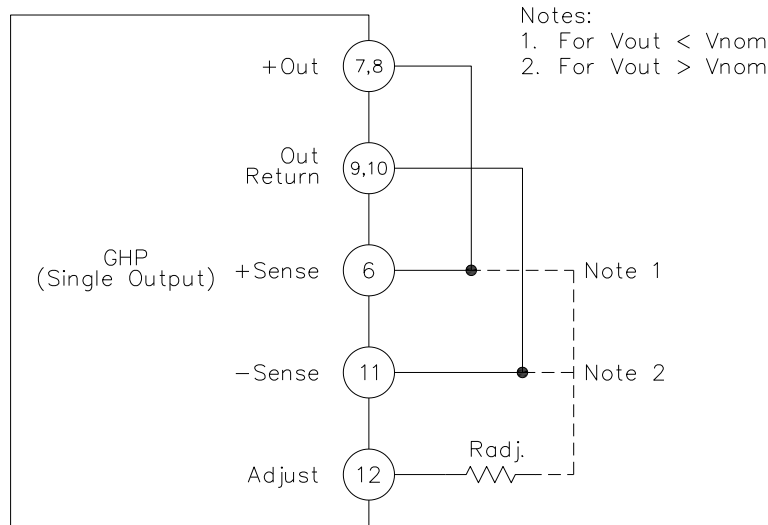

For **all Single Output Models**, to adjust the output voltages higher:

$$R_{ADJ} = \frac{10 \times (V_{NOM} - 2.5)}{V_{OUT} - V_{NOM}} - 50$$

Where: R_{ADJ} is in kOhms

R_{ADJ} is connected to the -Out pin and $V_{NOM} < V_{OUT} < 1.1V_{NOM}$ (Fig. 3, Note 2)

V_{NOM} is the nominal output voltage with the Adjust pin left open

V_{OUT} is the desired output voltage

For **all Single Output Models**, to adjust the output voltages lower:

$$R_{ADJ} = \frac{4 \times (V_{NOM} - 2.5) \times (V_{OUT} - 2.5)}{V_{NOM} - V_{OUT}} - 50$$

Where: R_{ADJ} is in kOhms

R_{ADJ} is connected to the +Out pin and $0.8V_{NOM} < V_{OUT} < V_{NOM}$ (Fig. 3, Note 1)

V_{NOM} is the nominal output voltage with the Adjust pin left open

V_{OUT} is the desired output voltage

Dual Output:

To adjust the output voltage of the dual output models, a resistor (R_{ADJ}) is connected between the Adjust pin (Pin 8) and either output. This allows the outputs to be reliably adjusted by approximately +10% to -20% of the nominal output voltage. Refer to Figure 9 and use equations provided to calculate the required resistance (R_{ADJ}).

Fig 4. Configuration for Adjusting Dual Output Voltage

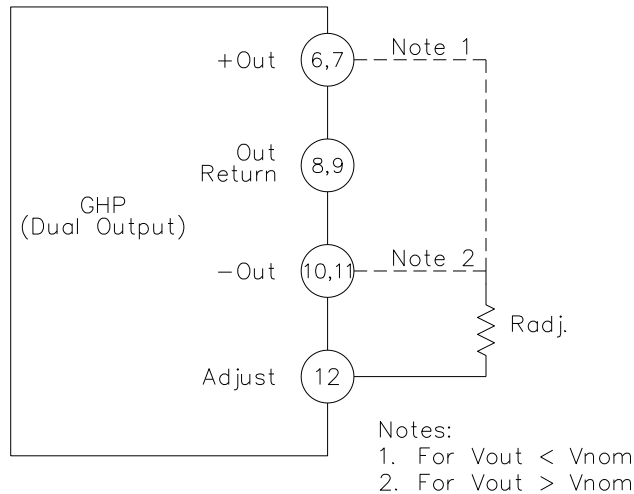

For all Dual Output Models, to adjust the output voltages higher:

$$R_{ADJ} = \frac{10 \times (V_{NOM} - 1.25)}{V_{OUT} - V_{NOM}} - 75$$

Where: R_{ADJ} is in kOhms
 R_{ADJ} is connected to the -Out pin and $V_{NOM} < V_{OUT} < 1.1V_{NOM}$ (Fig. 4, Note 2)
 V_{NOM} is the nominal output voltage with the Adjust pin left open
 V_{OUT} is the desired output voltage

For all Dual Output Models, to adjust the output voltages lower:

$$R_{ADJ} = \frac{8 \times (V_{NOM} - 1.25) \times (V_{OUT} - 1.25)}{V_{NOM} - V_{OUT}} - 75$$

Where: R_{ADJ} is in kOhms
 R_{ADJ} is connected to the +Out pin and $0.8V_{NOM} < V_{OUT} < V_{NOM}$ (Fig. 4, Note 1)
 V_{NOM} is the nominal output voltage with the Adjust pin left open
 V_{OUT} is the desired output voltage

Mechanical Outline

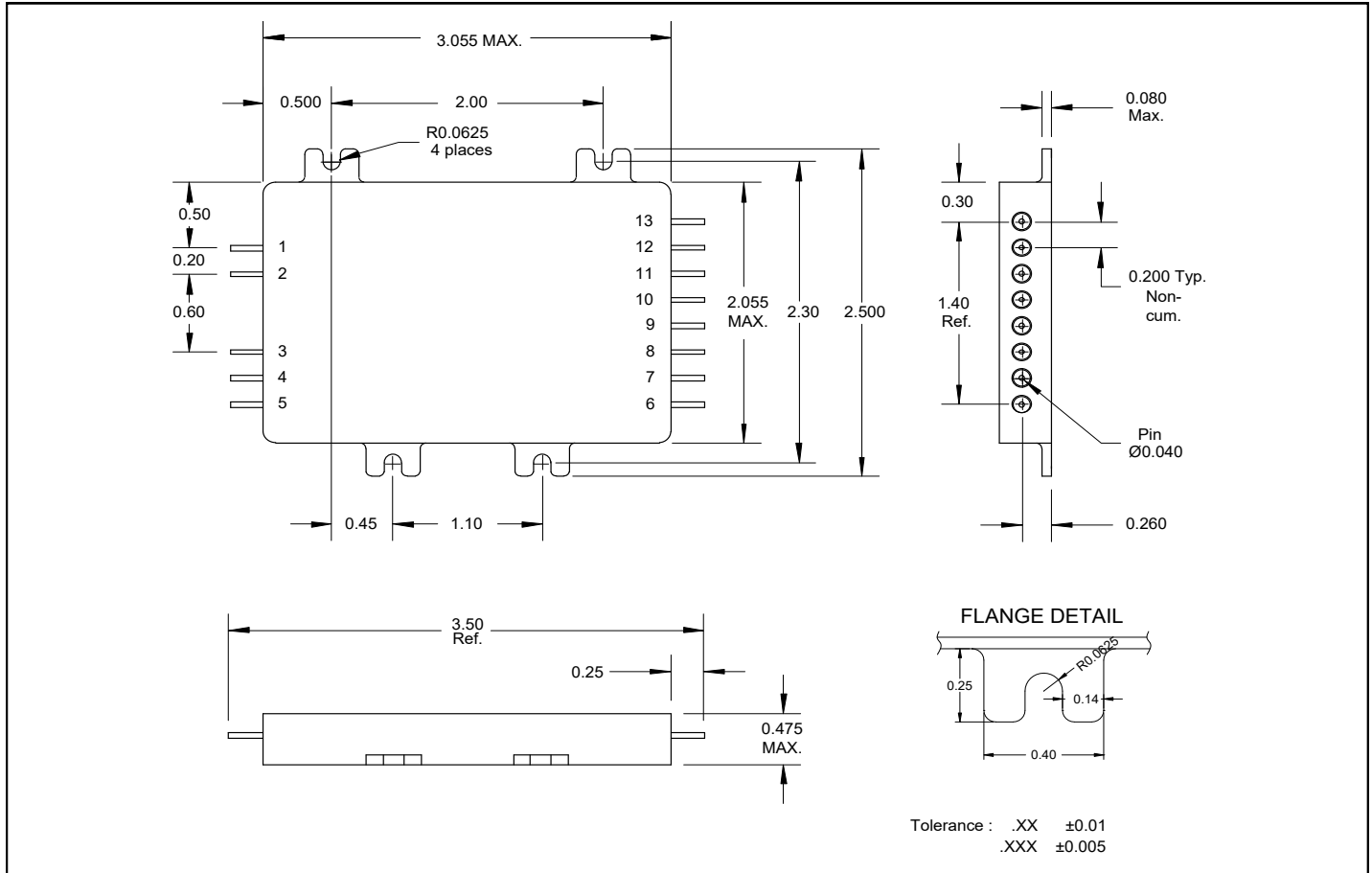

Pin Designation (Single/Dual)

Single Output		Dual Output	
Pin #	Designation	Pin #	Designation
1	Input	1	Input
2	Input Return	2	Input Return
3	Inhibit	3	Inhibit
4	Sync. Input	4	Sync. Input
5	Sync. Output	5	Sync. Output
6	+ Sense	6	+ Output
7	Output	7	+ Output
8	Output	8	Output Return
9	Output Return	9	Output Return
10	Output Return	10	- Output
11	- Sense	11	- Output
12	Output Adjust	12	Output Adjust
13	Case Ground	13	Case Ground

Device Screening

Part Number Designator		/EM ①	/CK ②
Compliance Level	MIL-PRF-38534	—	K level compliant
Certification Mark		—	CK
Screening Requirement	MIL-STD-883 Method	—	—
Temperature Range	—	Room Temperature	-55°C to +85°C
Element Evaluation	MIL-PRF-38534	N/A	Class K
Non-Destructive Bond Pull	2023	N/A	Yes
Internal Visual	2017	IR Defined	Yes
Temperature Cycle	1010	N/A	Cond C
Constant Acceleration	2001, Y1 Axis	N/A	3000 Gs
PIND	2020	N/A	Cond A
Burn-In	1015	N/A	320 hrs @ 125°C (2 x 160 hrs)
Final Electrical (Group A)	MIL-PRF-38534 & Specification	Room Temperature	-55°C, +25°C, +85°C
PDA	MIL-PRF-38534	N/A	2%
Seal, Fine and Gross	1014	N/A	Cond CH
Radiographic	2012	N/A	Yes
External Visual	2009	IR Defined	Yes

Notes:

- ① **"EM" grade** parts are strictly intended to permit the customer to determine the electrical functionality of the device in the customer's application in ambient conditions. The use of EM devices in production applications presents an unquantifiable risk of failure and IR HiRel disclaims all responsibility for such failure.
- ② **"CK" grade** is the flight model (FM) compliant to K Level screening as defined in the DLA Land and Maritime MIL-PRF-38534 requirements, but is not necessarily a DLA Land and Maritime qualified SMD per MIL-PRF-38534. The governing document for this part number designator is the IR HiRel datasheet (this document). Radiation rating as stated in the "Radiation Performance Characteristics" section, is verified by analysis and test per IR HiRel internal procedure. The part is marked with the IR base part number and the "CK" certification mark.

Part Numbering

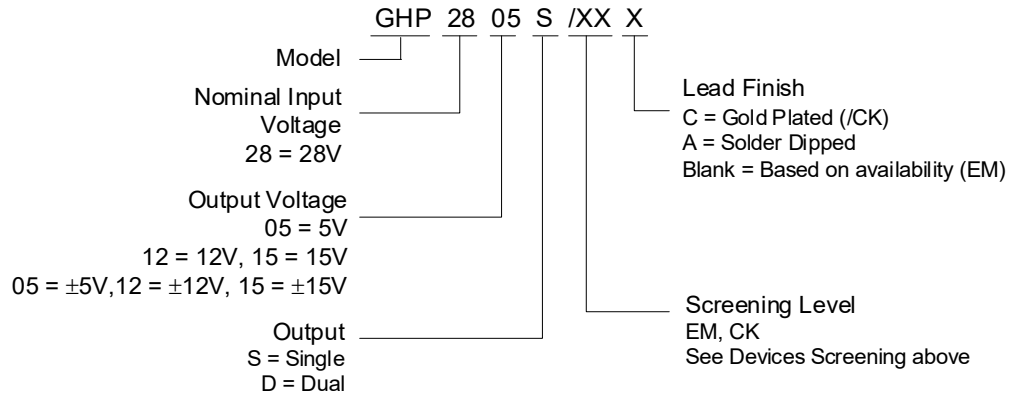

Orderable Part Numbers and DLA SMD Numbers

If a DLA SMD is available as listed in the table below, such model shall be ordered using the DLA SMD number. Otherwise the model shall be ordered using the part number nomenclature.

Reference IR Base Model	Orderable Part Number	Lead finish
GHP2815S/CKA	5962-1021801KXA	Solder Dipped
GHP2815S/CKC	5962-1021801KXC	Gold Plated