

GHP-SERIES

PD-97897D

Hybrid – High Reliability Radiation Hardened DC-DC Converter 100V Input, Single and Dual Output

Features

- Total Dose > 100 kRads(Si)
- SEE Hardened to LET up to 82 MeV·cm²/mg
- Low Weight < 110 grams
- Low Input and Output Noise
- Magnetically Coupled Feedback
- 65V to 110V DC Input Range
- Up to 120W Output Power
- Single and Dual Output Models
Include 3.3, 5, 12, 15, ±5, ±12 and ±15V
- High Efficiency - to 87%
- -55°C to +125°C Operating Temperature Range
- 100MΩ @ 500VDC Isolation
- Under-Voltage Lockout
- Short Circuit and Overload Protection
- Adjustable Output with an External Resistor
- Remote Sense on Single Output Models
- Synchronization Input and Output
- External Inhibit
- 3.3 Million-hour MTBF

Product Summary

- **Part number:** GHP10003R3S, GHP10005S, GHP10012S, GHP10015S, GHP10005D, GHP10012D, GHP10015D

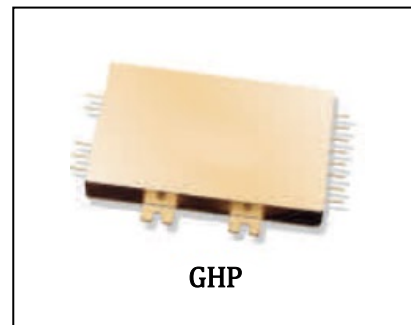

Potential Applications

- Geostationary Earth Orbit Satellites (GEO)
- Deep Space Satellites / Probes

Product Validation

Validated according to MIL-PRF- 38534 for high-reliability applications

Ordering Information

Ordering Information

Orderable Part Numbers

Part Number	Package	Screening Level
GHP10003R3S/CKA	Solder Dipped	Class K
GHP10003R3S/CKC	Gold Plated	Class K
GHP10005S/CKA	Solder Dipped	Class K
GHP10005S/CKC	Gold Plated	Class K
GHP10012S/CKA	Solder Dipped	Class K
GHP10012S/CKC	Gold Plated	Class K
GHP10015S/CKA	Solder Dipped	Class K
GHP10015S/CKC	Gold Plated	Class K
GHP10005D/CKA	Solder Dipped	Class K
GHP10005D/CKC	Gold Plated	Class K
GHP10012D/CKA	Solder Dipped	Class K
GHP10012D/CKC	Gold Plated	Class K
GHP10015D/CKA	Solder Dipped	Class K
GHP10015D/CKC	Gold Plated	Class K

Description

The GHP-Series of DC-DC converters are radiation hardened, high reliability converters specifically designed in response to the need for moderate power, high efficiency and well-regulated output required by the modern-day space design applications. Their small size and low weight make them ideal for applications such

as geostationary earth orbit satellites and deep space probes. They exhibit a high tolerance to total ionizing dose, single event effects and environmental stresses such as temperature extremes, mechanical shock, and vibration.

The converters incorporate a fixed frequency single ended forward topology with magnetic feedback and an internal EMI filter that utilizes multilayer ceramic capacitors that are subjected to extensive lot screening for optimum reliability. By using two stage filtering these converters produce low input and output noise. External inhibit and synchronization input and output allow these converters to be easily incorporated into larger power systems. They are enclosed in a hermetic 3" x 2" x 0.475" package constructed of an Aluminum-Silicon-Carbide (AlSiC) base and an Alloy 48 ring frame and they weigh less than 110 grams. The package utilizes rugged ceramic feed-through copper core pins and is sealed using parallel seam welding.

Manufactured in a facility fully qualified to MIL-PRF-38534, these converters are fabricated utilizing DLA Land and Maritime qualified processes. For available screening options, refer to device screening table in the data sheet

Non-flight versions of the GHP-Series converters are available for system development purposes. Variations in electrical specifications and screening to meet custom requirements can be accommodated

Table of contents

Features 1

Product Summary 1

Potential Applications 1

Product Validation..... 1

Ordering Information 2

Orderable Part Numbers.....	2
Description	2
Table of contents.....	3
1 Specification and Electrical Performance	5
1.1 Maximum and Operating Table	5
1.2 Electrical Performance Characteristics	5
Notes: Electrical Performance Characteristics Table	9
2 Block Diagram.....	10
3 Radiation Performance table and Application Notes.....	11
3.1 Radiation Performance table	11
3.2 Application Notes	11
4 Mechanical Outlines	15
5 Pin Designation.....	16
5.1 Pin Designation (Single / Dual)	16
6 Devices Screening	17
Part Numbering.....	18
Revision history	19

Specification and Electrical Performance

1 Specification and Electrical Performance

1.1 Maximum and Operating Table

Table 1 Absolute Maximum Rating and Recommended Operating Conditions

Absolute Maximum Rating		Recommended Operating Conditions	
Input voltage	-0.5V _{DC} to +120V _{DC}	Input voltage ¹	+65V _{DC} to +110V _{DC}
Output power	Internally limited	Output power	0 to Max. Rated
Lead Temperature	+300°C for 10 seconds	Operating Temperature	-55°C to +85°C
Operating Temperature	-55°C to +125°C		
Storage Temperature	-55°C to +125°C		

1.2 Electrical Performance Characteristics

Table 2 Electrical Characteristics

Parameter	Group A Subgroups	Conditions -55°C ≤ T _c ≤ +85°C V _{IN} = 100V DC ± 5%, C _L = 0uF unless otherwise specified	Limits			Unit	
			Min	Nom	Max		
Input voltage (V _{IN})			65	100	110	V	
Output Voltage (V _{OUT})	1	I _{OUT} = 100% rated load Note 4	3.28	3.30	3.32	V	
	1		4.98	5.00	5.02		
	GHP10003R3S		1	11.95	12.0		12.05
	GHP10005S		1	14.94	15.0		15.06
	GHP10012S		1	±4.95	±5.0		±5.05
	GHP10015S		1	±11.95	0		±12.0
	GHP10005D		1	±14.94	±12.0		5
	GHP10012D			0	±15.0		
	GHP10015D	2,3	I _{OUT} = 100% rated load Note 4	3.24	±15.0		6
		2,3		4.93	0		
	GHP10003R3S	2,3		11.84			3.36
	GHP10005S	2,3		14.80			5.07
	GHP10012S	2,3		±4.90			12.16
	GHP10015S	2,3		±11.84			15.20
	GHP10005D	2,3		±14.80			±5.10
	GHP10012D						±12.1
	GHP10015D						6
					±15.2		
				0			

For Notes to Electrical Performance Characteristics, refer to page 9

¹ Meets de-rating per MIL-STD-975

GHP-SERIES

100V Input, Single and Dual Output

Specification and Electrical Performance

Parameter	Group A Subgroups	Conditions -55°C ≤ T _c ≤ +85°C V _{IN} = 100V DC ± 5%, C _L = 0uF unless otherwise specified	Limits			Unit	
			Min	Nom	Max		
Output power (P _{OUT})							
GHP10003R3S			0		66		
GHP10005S			0		100		
GHP10012S	1,2,3	V _{IN} = 65, 100, 110 Volts, Note 2	0		120	W	
GHP10015S			0		120		
GHP10005D			0		100		
GHP10012D			0		100		
GHP10015D			0		100		
Output current (I _{OUT})							
GHP10003R3S		V _{IN} = 65, 100, 110 Volts, Note 2	0		20		A
GHP10005S			0		20		
GHP10012S	1,2,3		0		10		
GHP10015S			0		8.0		
GHP10005D		Either Output, Note 3	3.2		16		
GHP10012D		Either Output, Note 3	1.6		6.67		
GHP10015D		Either Output, Note 3	1.3		5.3		
Line regulation (VR _{LINE})	1,2,3	V _{IN} = 65, 100, 110 Volts, I _{OUT} = 0, 50%, 100% rated, Note 4	-10		-10	mV	
Load regulation (VR _{LOAD})	1,2,3	I _{OUT} = 0, 50%, 100% rated, Note 4 V _{IN} = 65, 100, 110 Volts,	-0.5		0.5	%	
Cross regulation (VR _{CROSS})							
GHP10005D	1,2,3	Duals only, Note 5	-5.0		5.0	%	
GHP10012D		V _{IN} = 65, 100, 110 Volts,	-3.0		3.0		
GHP10015D			-3.0		3.0		
Total regulation (Line, Load, and Temperature)	1,2,3	V _{IN} = 65, 100, 110 Volts, I _{OUT} = 0, 50%, 100% rated, Dual Model is measured From +Output to -Output, Note 14	-2.0		2.0	%	
Input current (I _{IN})	1,2,3	I _{OUT} = 0, Pin 3 open Pin 3 shorted to Pin 2		70 2.5	100 5.0	mA	

For Notes to Electrical Performance Characteristics, refer to page 9

GHP-SERIES
100V Input, Single and Dual Output

Specification and Electrical Performance

Parameter	Group A Subgroups	Conditions $-55^{\circ}\text{C} \leq T_c \leq +85^{\circ}\text{C}$ $V_{IN} = 100\text{V DC} \pm 5\%$, $C_L = 0\mu\text{F}$ unless otherwise specified	Limits			Unit
			Min	Nom	Max	
Output ripple (V_{RIP}) GHP10003R3S GHP10005S GHP10012S GHP10015S GHP10005D GHP10012D GHP10015D	1,2,3	$V_{IN} = 65, 100, 110$ Volts, $I_{OUT} = 100\%$ rated load Notes 4, 6		10 15 25 25 20 20 20	50 50 60 60 60 60 60	mV _{p-p}
Input ripple current	1,2,3	$I_{OUT} = 100\%$ rated load, Note 1		7.0	18	mA _{rms}
Switching frequency (F_S)	1,2,3	Sync. Input (Pin 4) open	450	500	550	kHz
Efficiency (E_{FF}) GHP10003R3S GHP10005S GHP10012S GHP10015S GHP10005D GHP10012D GHP10015D	1,2,3	$I_{OUT} = 100\%$ rated load Note 4	68 78 81 82 78 81 82	73 82 85 86 82 84 85		%
Inhibit Input Converter Off Sink current Converter On Sink current	1,2,3	Logic Low on Pin 3 Note 1 Logic High on Pin 3, Note 3 Note 1	-0.5 2.0		0.8 100 50 100	V μA V μA
Synchronization Input frequency range pulse high level pulse low level pulse transition time pulse duty cycle		Ext. Clock on Sync. Input (Pin 4), Note 1	450 4.0 -0.5 40 20		600 10 0.5 80	kHz V V V/ μs %
Current Limit Point Expressed as a percentage of full rated load current	1,2,3	$V_{OUT} = 90\%$ of Nominal, Note 4			145	%
Power dissipation, load fault (P_D)	1,2,3	Short Circuit, Overload, Note 8			35	W

For Notes to Electrical Performance Characteristics, refer to page 9

GHP-SERIES

100V Input, Single and Dual Output

Specification and Electrical Performance

Parameter	Group A Subgroups	Conditions -55°C ≤ T _c ≤ +85°C V _{IN} = 100V DC ± 5%, C _L = 0μF unless otherwise specified	Limits			Unit
			Min	Nom	Max	
Output response to step load changes (V _{TLD}) GHP10003R3S GHP10005S GHP10012S GHP10015S GHP10005D GHP10012D GHP10015D	4,5,6	Half Load to/from Full Load, Notes 4,9	-170 -450 -600 -750 -450 -750 -750		170 450 600 750 450 750 750	mVpk
Recovery time, step load changes (T _{TLD})	4,5,6	Half Load to/from Full Load, Notes 4,9,10			200	μs
Output response to step line changes (V _{TLN})		65V to/from 110V I _{OUT} = 100% rated load, Notes 1,4,11	-150		150	mVpk
Recovery time, step line changes (T _{TLN})		65V to/from 110V I _{OUT} = 100% rated load, Notes 1,4,10,11			200	μs
Turn-on Response Overshoot (V _{OS}) Turn-on Delay (T _{DLY})	4,5,6	No Load, Full Load Notes 4,12	1.0		2.0 8.0	% ms
Capacitive Load (C _L) GHP10003R3S GHP10005S GHP10012S GHP10015S GHP10005D GHP10012D GHP10015D		I _{OUT} = 100% rated load No effect on DC performance Notes 1,4,7 Each output on duals			6000 5000 1000 1000 1000 500 500	μF
Line Rejection		I _{OUT} = 100% rated load DC to 50kHz, Notes 1, 4	40			dB
Isolation	1	Input to Output or Any Pin to Case except Pin 6, test @ 500VDC	100			MΩ
Device Weight					110	g
MTBF		MIL-HDBK-217F2, SF, 35°C	3.3 x 10 ⁶			Hrs

For Notes to Electrical Performance Characteristics, refer to page 9

Notes: Electrical Performance Characteristics Table

Notes: Electrical Performance Characteristics Table

1. Parameter is tested as part of design characterization or after design changes. Thereafter, parameter shall be guaranteed to the limits specified.
2. Parameter verified during line and load regulation tests.
3. Output load current must be distributed such that at least 20% of the total load current is being provided by one of the outputs.
4. Load current split equally between outputs on dual output models.
5. Cross regulation is measured with 20% rated load on output under test while changing the load on the other output from 20% to 80% of rated.
6. Guaranteed for a D.C. to 20MHz bandwidth. Tested using a 20kHz to 10MHz bandwidth.
7. Capacitive load may be any value from 0 to the maximum limit without compromising dc performance. A capacitive load in excess of the maximum limit may interfere with the proper operation of the converter's overload protection, causing erratic behavior during turn-on.
8. Overload power dissipation is defined as the device power dissipation with the load set such that $V_{OUT} = 90\%$ of nominal.
9. Load step transition time $\geq 10 \mu s$.
10. Recovery time is measured from the initiation of the transient to where V_{OUT} has returned to within $\pm 1\%$ of its steady state value.
11. Line step transition time $\geq 100 \mu s$.
12. Turn-on delay time from either a step application of input power or a logic low to a logic high transition on the inhibit pin (pin 3) to the point where $V_{OUT} = 90\%$ of nominal.
13. Although operation at temperatures between $+85^{\circ}C$ and $+125^{\circ}C$ is guaranteed, no parametric limits are specified.
14. Total regulation at EOL is $\pm 3\%$ maximum.

Block Diagram

2 Block Diagram

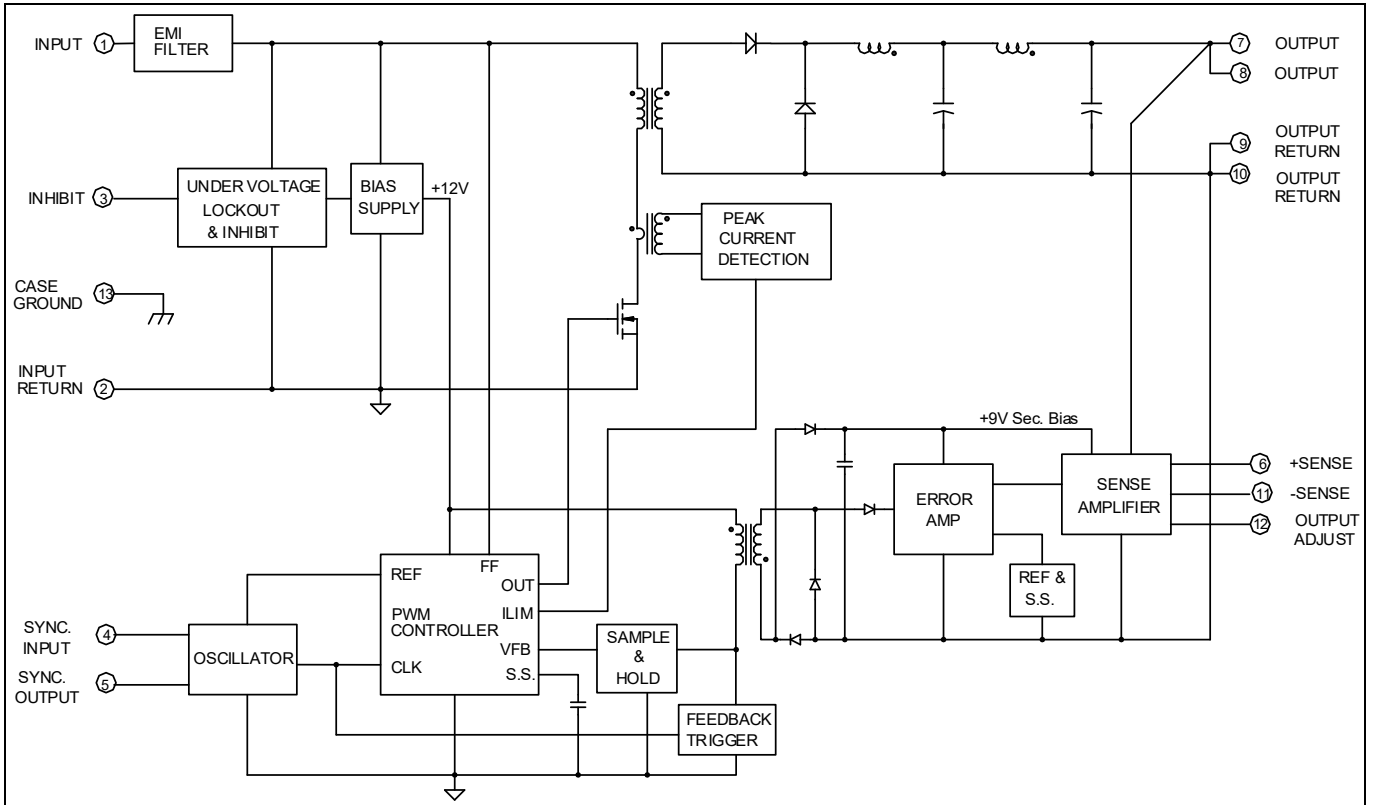

Figure 1 Block Diagram - Single Output

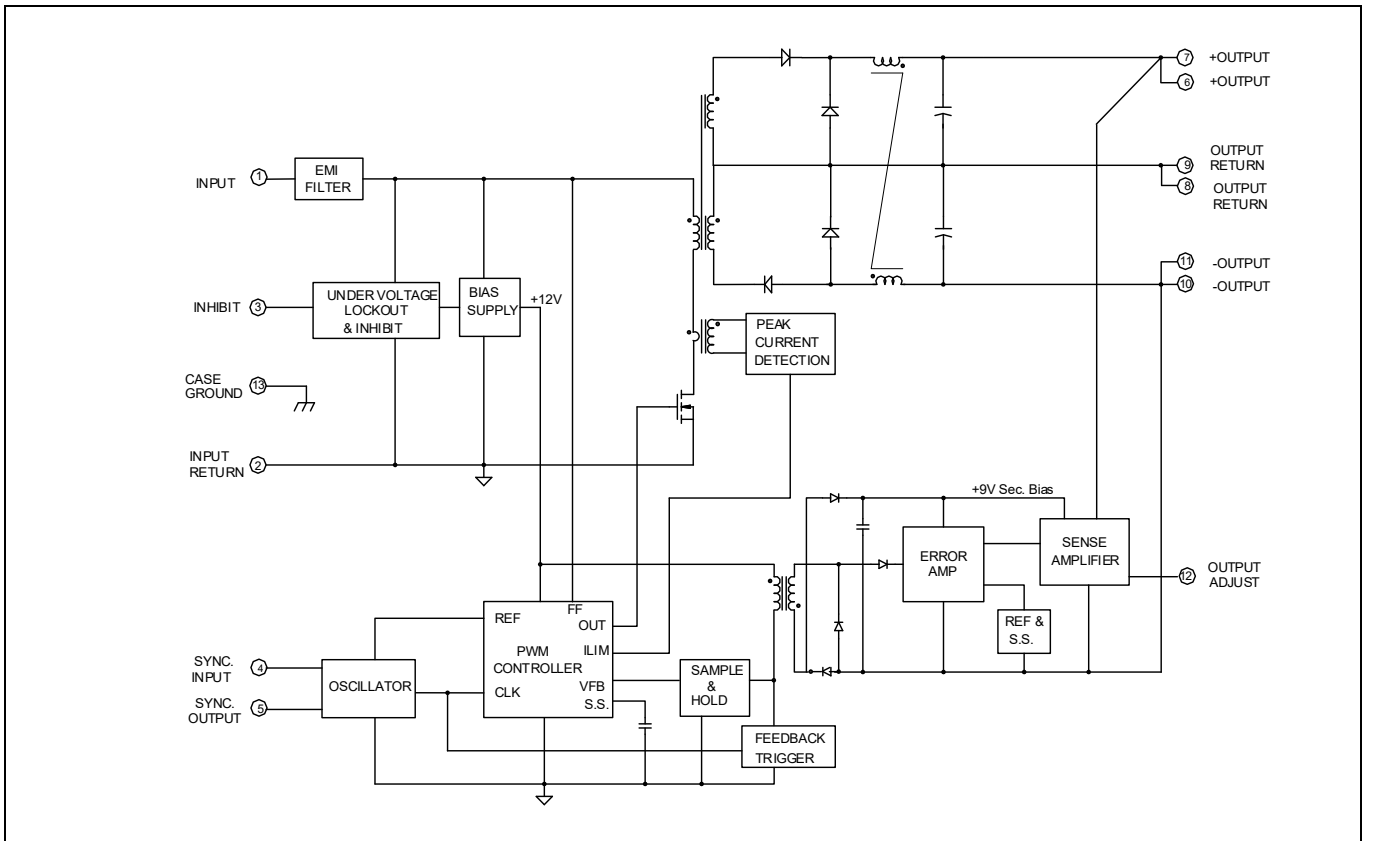

Figure 2 Block Diagram - Dual Output

3 Radiation Performance table and Application Notes

3.1 Radiation Performance table

Table 3 Radiation Performance Characteristics

Test	Conditions	Min	Typ	Unit
Total Ionizing Dose (Gamma)	MIL-STD-883, Method 1019 Operating bias applied during exposure, Full Rated Load, $V_{IN} = 100V$	100	150	kRads (Si)
Single Event Effects SEU, SEL, SEGR, SEB	Heavy ions (LET) Operating bias applied during exposure, Full Rated Load, $V_{IN} = 65, 100, 110V$ Test Lab: Texas A & M University	82		MeV·cm ² /mg

3.2 Application Notes

A) Attachment of the Converter:

The following procedure is recommended for mounting the converter for optimum cooling and to circumvent any potential damage to the converter.

Ensure that flatness of the plate where GHP converter to be mounted is no greater than 0.003" per linear inch. It is recommended that a thermally conductive gasket is used to promote the thermal transfer and to fill any voids existing between the two surfaces. IR HiRel recommends Sil-Pad 2000 with the thickness of 0.010". The shape of the gasket should match the footprint of the converter including the mounting flanges. The gasket is available from IR HiRel. The GHP-Series converter requires either M3 or 4-40 size screws of attachment purposes.

The procedure for mounting the converter is as follows:

1. Check the mounting surfaces and remove foreign material, burrs if any or anything that may interfere with the attachment of the converter.
2. Place the gasket on the surface reserved for the converter and line it up with the mounting holes.
3. Place the converter on the gasket and line both up with mounting holes.
4. Install screws using appropriate washers and tighten by hand (~ 4 in-oz) in the sequence shown below.

Radiation Performance table and Application Notes

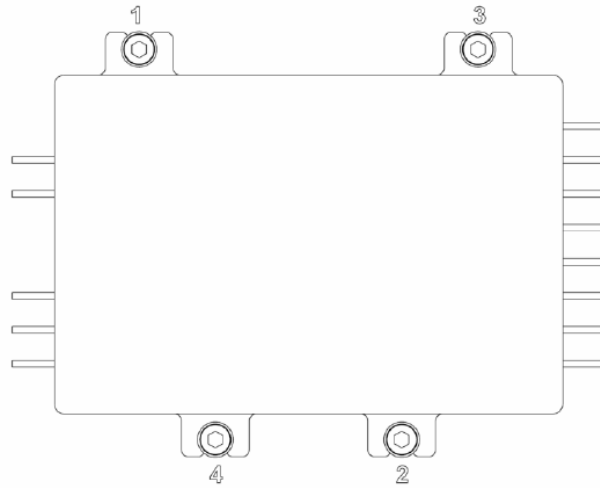

5. Tighten the screws with an appropriate torque driver. Torque the screws up to 6 in·lb in the sequence shown above

B) Output Voltage Adjustment

Single Output:

To adjust the output voltage of the single output models, a resistor (R_{ADJ}) is connected between the Adjust pin (Pin 12) and either the positive or negative remote sense pins, depending on whether the output voltage is to be adjusted higher or lower than the nominal set-point. This allows the outputs to be reliably adjusted by approximately +10% to -20% of the nominal output voltage. Refer to Fig. 3 and use equations provided to calculate the required resistance (R_{ADJ}).

Note: The output voltage adjust equation does not work as described for the 3.3V Single model. The adjust range for 3.3V model is limited to 3.252V to 3.460V.

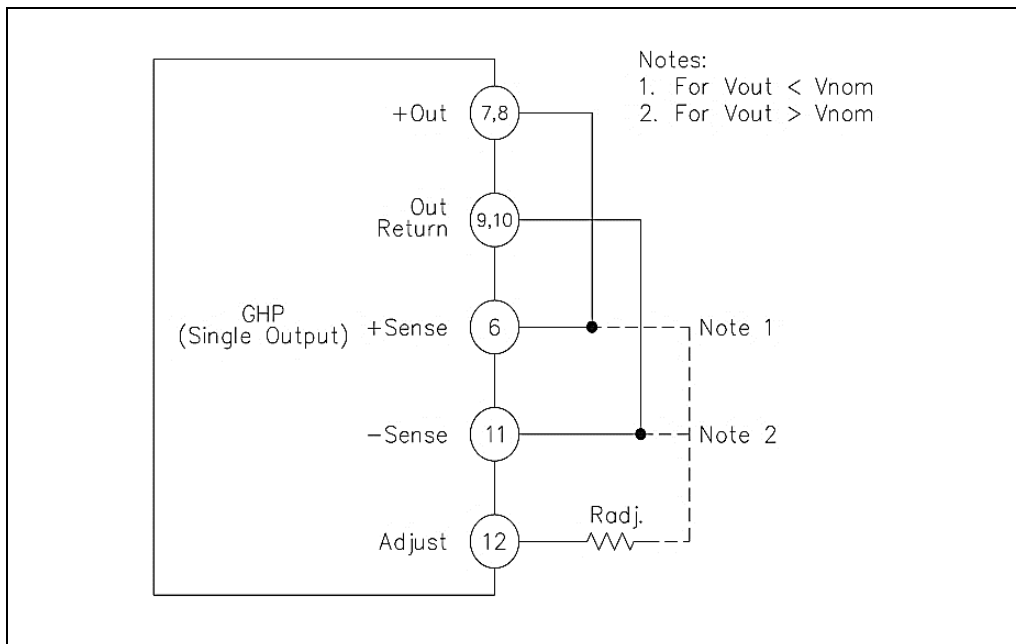

Figure 3 Configuration for Adjusting Single Output Voltage

Radiation Performance table and Application Notes

For all **Single Output Models**, to adjust the output voltages higher:

$$R_{ADJ} = \frac{10 \times (V_{NOM} - \square\square)}{V_{OUT} - V_{NOM}} - 50$$

To adjust the : R_{ADJ} is in kOhms

R_{ADJ} is connected to the -Out pin and $V_{NOM} < V_{OUT} < 1.1V_{NOM}$ (Fig. 3, Note 2)

V_{NOM} is the nominal output voltage with the Adjust Pin left open

V_{OUT} is the desired output voltage

For all **Single Output Models**, to adjust the output voltages lower:

$$R_{ADJ} = \frac{4 \times (V_{NOM} - \square\square) \times (V_{OUT} - \square\square)}{V_{NOM} - V_{OUT}} - 50$$

To adjust the: R_{ADJ} is in kOhms

R_{ADJ} is connected to the +Out pin and $0.8V_{NOM} < V_{OUT} < V_{NOM}$ (Fig.3, Note 1)

V_{NOM} is the nominal output voltage with the Adjust Pin left open

V_{OUT} is the desired output voltage

Dual Output:

To adjust the output voltage of the dual output models, a resistor (R_{ADJ}) is connected between the Adjust pin (Pin 8) and either output. This allows the outputs to be reliably adjusted by approximately +10% to -20% of the nominal output voltage. Refer to Fig. 4 and use equations provided to calculate the required resistance (R_{ADJ}).

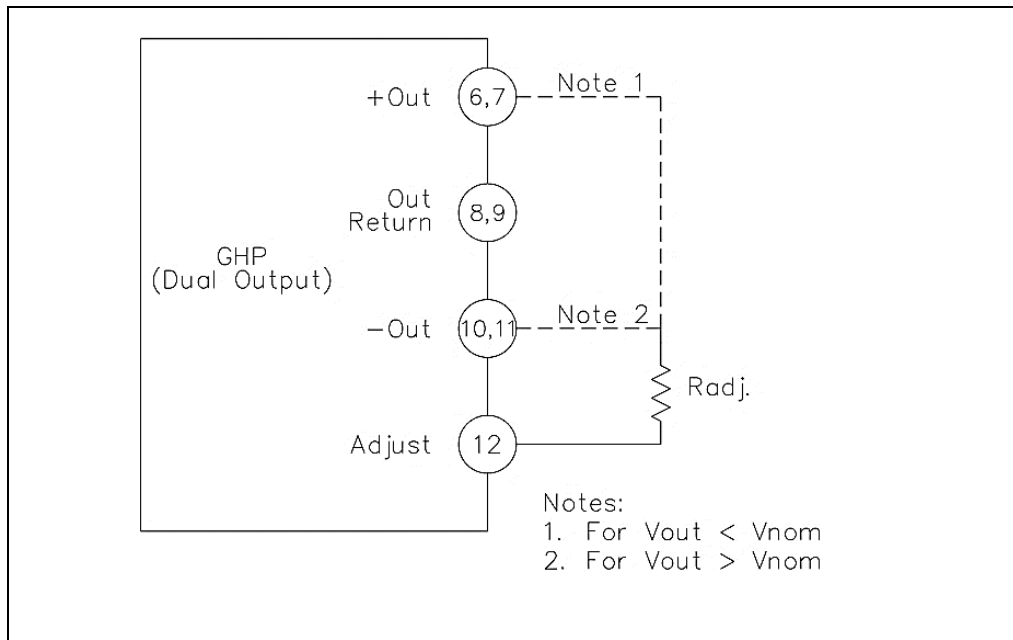

Figure 4 Configuration for Adjusting Dual Output Voltage

For all **Dual Output Models**, to adjust the output voltages higher:

GHP-SERIES

100V Input, Single and Dual Output

Radiation Performance table and Application Notes

$$R_{ADJ} = \frac{10 \times (V_{NOM} - \overset{\sim}{\square} \square \square)}{V_{OUT} - V_{NOM}} - 75$$

To adjust the: R_{ADJ} is in kOhms

R_{ADJ} is connected to the -Out pin and $V_{NOM} < V_{OUT} < 1.1V_{NOM}$ (Fig. 4, Note 2)

V_{NOM} is the nominal magnitude of the output voltages with the Adjust pin left open

V_{OUT} is the desired magnitude of the output voltages

For all **Dual Output Models**, to adjust the output voltages lower:

$$R_{ADJ} = \frac{8 \times (V_{NOM} - \overset{\sim}{\square} \square \square) \times (V_{OUT} - \overset{\sim}{\square} \square \square)}{V_{NOM} - V_{OUT}} - 75$$

To adjust the: R_{ADJ} is in kOhms

R_{ADJ} is connected to the +Out pin and $0.8V_{NOM} < V_{OUT} < V_{NOM}$ (Fig. 4, Note 1)

V_{NOM} is the nominal magnitude of the output voltages with the Adjust pin left open

V_{OUT} is the desired magnitude of the output voltages

Mechanical Outlines

4 Mechanical Outlines

Note: For the most updated package outline, please see the website: [GHP-SERIES](#)

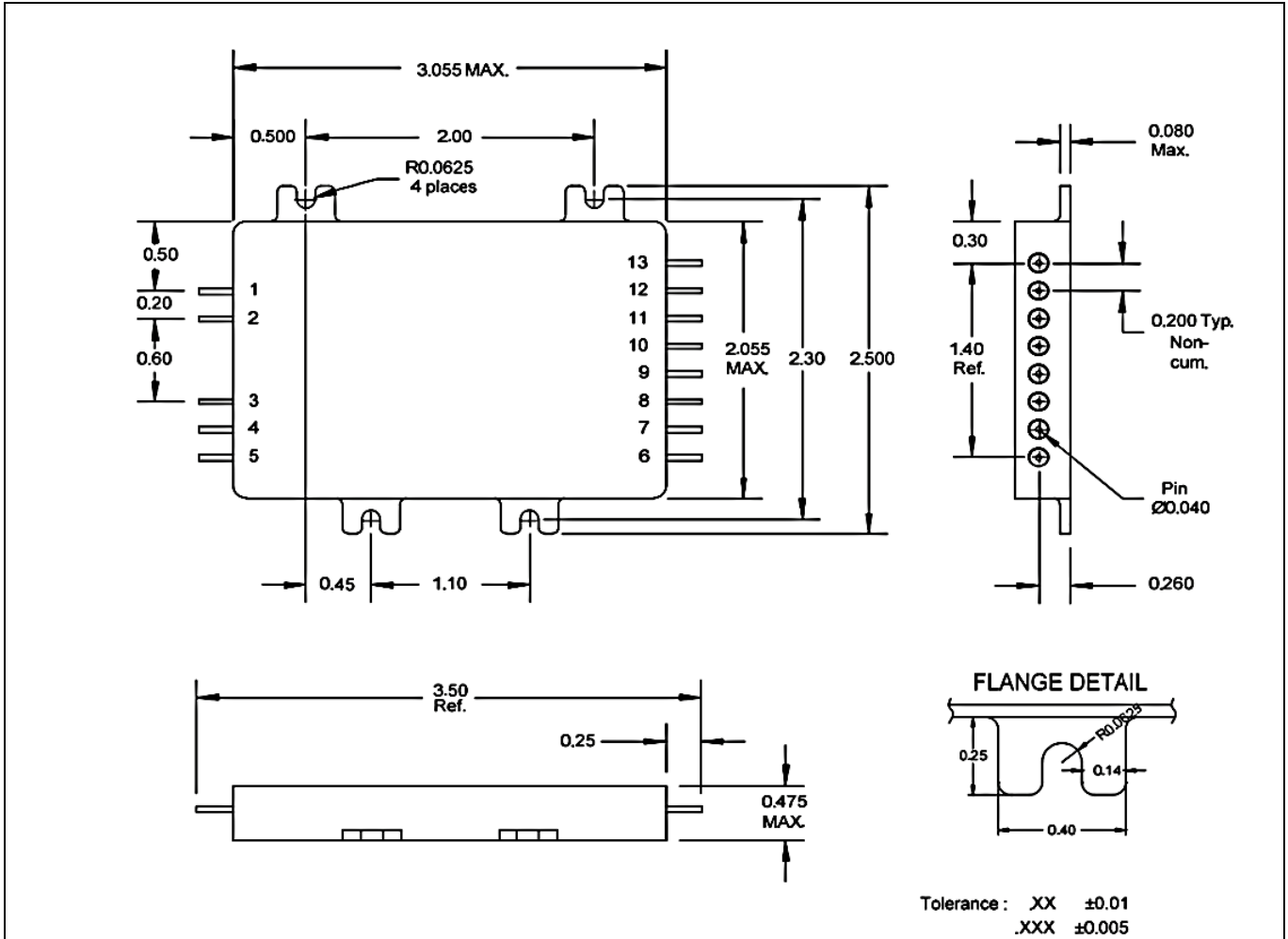

Figure 5 Package outline

Pin Designation

5 Pin Designation

5.1 Pin Designation (Single / Dual)

Table 4 Designation

Single Output		Dual Output	
Pin Number	Designation	Pin Number	Designation
1	Input	1	Input
2	Input Return	2	Input Return
3	Inhibit	3	Inhibit
4	Sync. Input	4	Sync. Input
5	Sync. Output	5	Sync. Output
6	+Sense	6	+ Output
7	Output	7	+ Output
8	Output	8	Output Return
9	Output Return	9	Output Return
10	Output Return	10	-Output
11	-Sense	11	-Output
12	Output Adjust	12	Output Adjust
13	Case Ground	13	Case Ground

Devices Screening

6 Devices Screening

Part Number Designator		/EM ^①	/CK ^②
Compliance Level	MIL-PRF-38534	—	K level compliant
Certification Mark		—	CK
Screening Requirement	MIL-STD-883 Method	—	—
Temperature Range	—	Room Temperature	-55°C to +85°C
Element Evaluation	MIL-PRF-38534	N/A	Class K
Non-Destructive Bond Pull	2023	N/A	Yes
Internal Visual	2017	IR Defined	Yes
Temperature Cycle	1010	N/A	Cond C
Constant Acceleration	2001, Y1 Axis	N/A	3000 Gs
PIND	2020	N/A	Cond A
Burn-In	1015	N/A	320 hrs @ 125°C (2 x 160 hrs)
Final Electrical (Group A)	MIL-PRF-38534 & Specification	Room Temperature	-55°C, +25°C, +85°C
PDA	MIL-PRF-38534	N/A	2%
Seal, Fine and Gross	1014	N/A	Cond CH
Radiographic	2012	N/A	Yes
External Visual	2009	IR Defined	Yes

Notes:

- ① **"EM" grade** parts are strictly intended to permit the customer to determine the electrical functionality of the device in the customer's application in ambient conditions. The use of EM devices in production applications presents an unquantifiable risk of failure and IR HiRel disclaims all responsibility for such failure.
- ② **"CK" grade** is the flight model (FM) compliant to K Level screening as defined in the DLA Land and Maritime MIL-PRF-38534 requirements, but is not necessarily a DLA Land and Maritime qualified SMD per MIL-PRF-38534. The governing document for this part number designator is the IR HiRel datasheet (this document). Radiation rating as stated in the "Radiation Performance Characteristics" section, is verified by analysis and test per IR HiRel internal procedure. The part is marked with the IR base part number and the "CK" certification mark.

GHP-SERIES

100V Input, Single and Dual Output

Part Numbering

Part Numbering

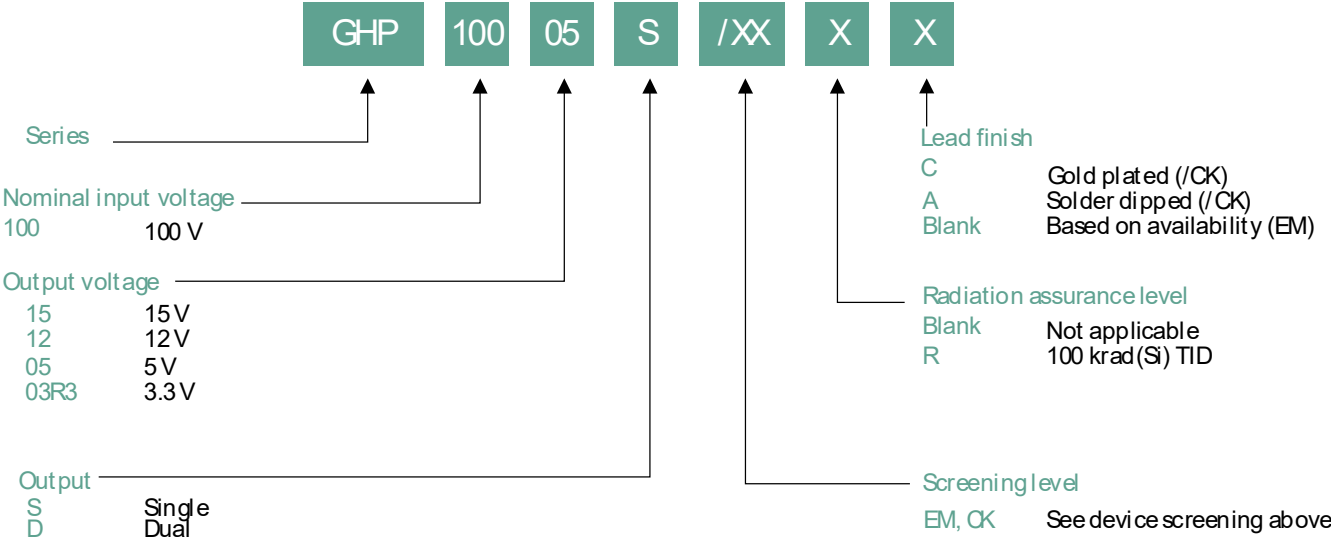

Revision history

Revision history

Document version	Date of release	Description of changes
	02/21/2018	Datasheet (PD-97897)
Rev A	02/11/2022	Updated based on ECO-1110_29655
Rev B	04/30/2020	Updated based on ECO-1110_29731
Rev C	08/30/2021	Updated based on ECO-1110_30394
Rev D	01/20/2023	Updated based on ECO-1110_30895

Need Information?