

## **ATO28XXT SERIES**

### **28V Input, Triple Output**

## **HYBRID-HIGH RELIABILITY DC/DC CONVERTER**

### **Description**

The ATO28XXT Series of DC/DC converters feature high power density and an extended temperature range for use in military and industrial applications. Designed to the nominal input requirements of MIL-STD-704D, these devices have nominal 28VDC inputs with +5V and  $\pm 12V$  or +5V and  $\pm 15V$  triple outputs to satisfy a wide range of requirements. The circuit design incorporates a pulse width modulated push-pull topology operating in the feed-forward mode at a nominal switching frequency of 250KHz. Input to output isolation is achieved through the use of transformers in the forward and feedback circuits.

The advanced feedback design provides fast loop response for superior line and load transient characteristics and offers greater reliability and radiation tolerance than devices incorporating optical feedback circuits.

Three standard temperature grades are offered. Refer to Part Numbering section. They are provided in a standard plug-in package for PC mounting or in a flanged package for more severe environments.

Manufactured in a facility fully qualified to MIL-PRF-38534, these converters are fabricated utilizing DSCC qualified processes. For available screening options, refer to device screening table in the data sheet. Variations in electrical, mechanical and screening can be accommodated. Extensive computer simulation using complex modeling enables modest design modifications to be accommodated. Contact IR Santa Clara with specific requirements.

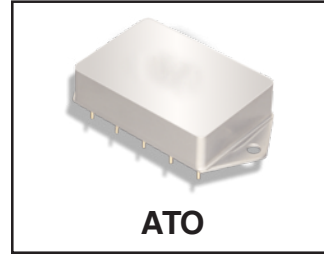

### **Features**

- 16V to 40VDC Input Range (28VDC Nominal)
- 5V,  $\pm 12V$  or 5V,  $\pm 15V$  Outputs Available
- Indefinite Short Circuit and Overload Protection
- 15W Output Power
- Fast Loop Response for Superior Transient Characteristics
- Operating Temperature Range from  $-55^{\circ}\text{C}$  to  $+125^{\circ}\text{C}$  Available
- Popular Industry Standard Pin-out
- Resistance Seam Welded Case for Superior Long Term Hermeticity
- Efficiencies up to 81%
- Shutdown from External Signal
- 200,000 Hour MTBF at  $85^{\circ}\text{C}$
- Standard Microcircuit Drawings Available

## ATO28XXT Series



### Specifications

$T_{CASE} = -55^{\circ}\text{C}$  to  $+85^{\circ}\text{C}$ ,  $V_{IN} = +28\text{V} \pm 5\%$  unless otherwise specified

Absolute Maximum Ratings		
Input voltage	-0.5V to +50VDC	
Power Output	Internally limited, 17.5W typical	
Soldering temperature	300°C for 10 seconds	
Temperature Range <sup>6</sup>	Operating case temperature	-55°C to +115°C
	Storage case temperature	-65°C to +135°C

TEST	SYMBOL	Condition -55°C ≤ T <sub>C</sub> ≤ +85°C, V <sub>IN</sub> = 28 VDC ±5%, C <sub>L</sub> =0 unless otherwise specified	ATO2812T		ATO2815T		Units	
			Min	Max	Min	Max		
STATIC CHARACTERISTICS OUTPUT Voltage <sup>1</sup>	V <sub>OUT</sub>	I <sub>OUT</sub> = 0 (main)	TC = 25°C	4.95	5.05	4.95	5.05	V
		I <sub>OUT</sub> = 0 (dual) <sup>1</sup>	Over Temp	4.90	5.10	4.90	5.10	V
Current <sup>1,2,3</sup>	I <sub>OUT</sub>	V <sub>IN</sub> = 16, 28, and 40 VDC (main)	TC = 25°C	±11.88	±12.12	±14.85	±15.15	V
		V <sub>IN</sub> = 16, 28, and 40 VDC (dual) <sup>1</sup>	Over Temp	±11.76	±12.24	±14.70	±15.30	V
Ripple Voltage <sup>1,4</sup>	V <sub>RIP</sub>	V <sub>IN</sub> = 16, 28, and 40 VDC (main)		0.0	2000	0.0	2000	mA
		V <sub>IN</sub> = 16, 28, and 40 VDC (dual)		0.0	±208	0.0	±167	mA
Power <sup>1,2,3</sup>	P <sub>OUT</sub>	BW = DC to 2 MHz (main)			80		80	mVp-p
		BW = DC to 2 MHz (dual)			40		40	mVp-p
REGULATION Line <sup>1,3</sup>	V <sub>RLINE</sub>	V <sub>IN</sub> = 16, 28, and 40 VDC			25		25	mV
		I <sub>OUT</sub> = 0, 1000, 2000mA (main)	TC = 25°C Over Temp		±30		±35	
		V <sub>IN</sub> = 16, 28, and 40 VDC (dual)			±60		±75	
		I <sub>OUT</sub> = 0, ±84, ±167mA (dual)			50		50	
V <sub>IN</sub> = 16, 28, and 40 VDC		±60			±75			
INPUT Current	I <sub>IN</sub>	I <sub>OUT</sub> = 0, Inhibit (pin 8)			15		15	mA
		Tied to input return (pin 10)			40		40	mA
Ripple Current <sup>4</sup>	I <sub>RIP</sub>	I <sub>OUT</sub> = 0, inhibit (pin 2) = open			50		50	mA
EFFICIENCY	E <sub>FF</sub>	I <sub>OUT</sub> = 2000mA (main)	TC = 25°C	76		76		%
		I <sub>OUT</sub> = ±167mA (dual)						
ISOLATION	ISO	Input to output or any pin to case (except pin 7) at 500 VDC	TC = 25°C	100		100		MΩ
Load Fault Power Dissipation <sup>3</sup>	P <sub>D</sub>	Overload	TC = 25°C		8.0		8.0	W
Short Circuit				6.0		6.0		
Switching Frequency	F <sub>S</sub>	I <sub>OUT</sub> = 2000mA (main)		225	275	225	275	KHz
Inhibit Open Circuit Voltage	V <sub>OI</sub>	I <sub>OUT</sub> = ±167mA (dual)		9.0	13	9.0	13	V

### Notes to Specifications

1. Tested at each output.
2. Parameter guaranteed by line and load regulation tests.
3. At least 20 percent of the total output power should be taken from the (+5V) main output.
4. Bandwidth guaranteed by design. Tested for 20KHz to 2.0MHz.
5. An overload is that condition with a load in excess of the rated load but less than that necessary to trigger the short circuit protection and is the condition of maximum power dissipation.
6. Above 85°C case temperature, derate output power linearly to 0 at 115°C case.

T<sub>CASE</sub> = -55°C to +105°C, V<sub>IN</sub> = +28V ± 5% unless otherwise specified

Absolute Maximum Ratings		
Input voltage	-0.5V to +50VDC	
Power Output	Internally limited, 17.5W typical	
Soldering temperature	300°C for 10 seconds	
Temperature Range <sup>6</sup>	Operating case temperature	-55°C to +125°C
	Storage case temperature	-65°C to +135°C

TEST	SYMBOL	Condition -55°C ≤ T <sub>C</sub> ≤ +105°C, V <sub>IN</sub> = 28 V <sub>DC</sub> ±5%, C <sub>L</sub> =0 unless otherwise specified	ATO2812T/ES		ATO2815T/ES		Units	
			Min	Max	Min	Max		
STATIC CHARACTERISTICS								
Output Voltage <sup>1</sup>	V <sub>OUT</sub>	I <sub>OUT</sub> = 0 (main) I <sub>OUT</sub> = 0 (dual) <sup>1</sup>	TC = 25°C Over Temp	4.95 4.90	5.05 5.10	4.95 4.90	5.05 5.10	V V
Current <sup>1,2,3</sup>	I <sub>OUT</sub>	V <sub>IN</sub> = 16, 28, and 40 VDC (main) V <sub>IN</sub> = 16, 28, and 40 VDC (dual) <sup>1</sup>	TC = 25°C Over Temp	±11.88 ±11.76	±12.12 ±12.24	±14.85 ±14.70	±15.15 ±15.30	V V
Ripple Voltage <sup>1,4</sup>	V <sub>RIP</sub>	V <sub>IN</sub> = 16, 28, and 40 VDC BW = DC to 2 MHz (main) V <sub>IN</sub> = 16, 28, and 40 VDC BW = DC to 2 MHz (dual)		0.0 0.0	2000 ±208	0.0 80	2000 ±167	mA mVp-p
Power <sup>1,2,3</sup>	P <sub>OUT</sub>	V <sub>IN</sub> = 16, 28, and 40 VDC (main) (+dual) (-dual) (total)		10 2.5 2.5 15	40	10 2.5 2.5 15	40	W W W W
REGULATION								
Line <sup>1,3</sup>	VR <sub>LINE</sub>	V <sub>IN</sub> = 16, 28, and 40 VDC I <sub>OUT</sub> = 0, 1000, 2000mA (main) V <sub>IN</sub> = 16, 28, and 40 VDC (dual) I <sub>OUT</sub> = 0, ±84, ±167mA (dual)	TC = 25°C Over Temp		25 ±30 ±60 50		25 ±35 ±75 50	mV
Load <sup>1,3</sup>	VR <sub>LOAD</sub>	V <sub>IN</sub> = 16, 28, and 40 VDC I <sub>OUT</sub> = 0, 1000, 2000mA (main) V <sub>IN</sub> = 16, 28, and 40 VDC I <sub>OUT</sub> = 0, ±84, ±167mA (dual)			±60		±75	
INPUT								
Current	I <sub>IN</sub>	I <sub>OUT</sub> = 0, Inhibit (pin 8) Tied to input return (pin 10)			15		15	mA
Ripple Current <sup>4</sup>	I <sub>RIP</sub>	I <sub>OUT</sub> = 0, inhibit (pin 2) = open I <sub>OUT</sub> = 2000 mA (main) I <sub>OUT</sub> = ±167mA (dual) BW = DC to 2MHz			40 50		40 50	mA mA mA
EFFICIENCY	E <sub>FF</sub>	I <sub>OUT</sub> = 2000mA (main) I <sub>OUT</sub> = ±167mA (dual) TC = ±25°C	TC = 25°C	76		76		%
ISOLATION	ISO	Input to output or any pin to case (except pin 7) at 500 VDC	TC = 25°C	100		100		MΩ
Load Fault Power Dissipation <sup>3</sup>	P <sub>D</sub>	Overload, TC = +25°C <sup>5</sup> Short Circuit, TC = +25°C	TC = 25°C		8.0 6.0		8.0 6.0	W
Switching Frequency	F <sub>S</sub>	I <sub>OUT</sub> = 2000mA (main) I <sub>OUT</sub> = ±167mA (dual)		225	275	225	275	KHz
Inhibit Open Circuit Voltage	V <sub>OI</sub>			9.0	13	9.0	13	V

Notes to Specifications

1. Tested at each output.
2. Parameter guaranteed by line and load regulation tests.
3. At least 20 percent of the total output power should be taken from the (+5V) main output.
4. Bandwidth guaranteed by design. Tested for 20KHz to 2.0MHz.
5. An overload is that condition with a load in excess of the rated load but less than that necessary to trigger the short circuit protection and is the condition of maximum power dissipation.
6. Above 105°C case temperature, derate output power linearly to 0 at 125°C case

## ATO28XXT Series

### Specifications

$T_{CASE} = -55^{\circ}\text{C}$  to  $+125^{\circ}\text{C}$ ,  $V_{IN} = +28\text{V} \pm 5\%$  unless otherwise specified



Absolute Maximum Ratings		
Input voltage	-0.5V to +50VDC	
Power Output	Internally limited, 17.5W typical	
Soldering temperature	300°C for 10 seconds	
Temperature Range <sup>6</sup>	Operating case temperature	-55°C to +135°C
	Storage case temperature	-65°C to +135°C

TEST	SYMBOL	Condition -55°C ≤ TC ≤ +125°C, VIN = 28 VDC ±5%, CL=0 unless otherwise specified		ATO2812T/HB		ATO2815T/HB		Units
				Min	Max	Min	Max	
STATIC CHARACTERISTICS OUTPUT Voltage <sup>1</sup>	V <sub>OUT</sub>	I <sub>OUT</sub> = 0 (main)	TC = 25°C	4.95	5.05	4.95	5.05	V
		I <sub>OUT</sub> = 0 (dual) <sup>1</sup>		4.90	5.10	4.90	5.10	V
Current <sup>1,2,3</sup>	I <sub>OUT</sub>	V <sub>IN</sub> = 16, 28, and 40 VDC (main)	TC = 25°C	±11.88	±12.12	±14.85	±15.15	V
		V <sub>IN</sub> = 16, 28, and 40 VDC (dual) <sup>1</sup>		±11.76	±12.24	±14.70	±15.30	V
Ripple Voltage <sup>1,4</sup>	V <sub>RIP</sub>	V <sub>IN</sub> = 16, 28, and 40 VDC BW = DC to 2 MHz (main)	TC = 25°C	0.0	2000	0.0	2000	mA
		V <sub>IN</sub> = 16, 28, and 40 VDC BW = DC to 2 MHz (dual)		0.0	±208	0.0	±167	mA
Power <sup>1,2,3</sup>	P <sub>OUT</sub>	V <sub>IN</sub> = 16, 28, and 40 VDC (main)	TC = 25°C	80	80	80	80	mVp-p
		(+dual)		40	40	40	mVp-p	
		(-dual)		10	10	10	W	
		(total)		2.5	2.5	2.5	2.5	W
				15	15	15	15	W
REGULATION Line <sup>1,3</sup>	VR <sub>LINE</sub>	V <sub>IN</sub> = 16, 28, and 40 VDC I <sub>OUT</sub> = 0, 1000, 2000mA (main)	TC = 25°C		25		25	mV
Load <sup>1,3</sup>	VR <sub>LOAD</sub>	V <sub>IN</sub> = 16, 28, and 40 VDC (dual)		±30	±35			
		I <sub>OUT</sub> = 0, ±84, ±167mA (dual)	±60	±75				
		V <sub>IN</sub> = 16, 28, and 40 VDC	50	50				
		I <sub>OUT</sub> = 0, 1000, 2000mA (main)	±60	±75				
		V <sub>IN</sub> = 16, 28, and 40 VDC						
		I <sub>OUT</sub> = 0, ±84, ±167mA (dual)						
INPUT Current	I <sub>IN</sub>	I <sub>OUT</sub> = 0, Inhibit (pin 8) Tied to input return (pin 10)		15		15	mA	
Ripple Current <sup>4</sup>	I <sub>RIP</sub>	I <sub>OUT</sub> = 0, inhibit (pin 2) = open		40		40	mA	
		I <sub>OUT</sub> = 2000 mA (main)		50		50	mAp-p	
		I <sub>OUT</sub> = ±167mA (dual)						
		BW = DC to 2MHz						
EFFICIENCY	E <sub>FF</sub>	I <sub>OUT</sub> = 2000mA (main)	TC = 25°C	76		76	%	
		I <sub>OUT</sub> = ±167mA (dual)						
		TC = ±25°C						
ISOLATION	ISO	Input to output or any pin to case (except pin 7) at 500 VDC	TC = 25°C	100		100	MΩ	
Load Fault Power Dissipation <sup>3</sup>	P <sub>D</sub>	Overload, TC = +25°C <sup>5</sup>	TC = 25°C		8.0		8.0	W
		Short Circuit, TC = +25°C			6.0		6.0	
Switching Frequency	F <sub>S</sub>	I <sub>OUT</sub> = 2000mA (main)		225	275	225	275	KHz
		I <sub>OUT</sub> = ±167mA (dual)						
Inhibit Open Circuit Voltage	V <sub>OI</sub>			9.0	13	9.0	13	V

#### Notes to Specifications

1. Tested at each output.
2. Parameter guaranteed by line and load regulation tests.
3. At least 20 percent of the total output power should be taken from the (+5V) main output.
4. Bandwidth guaranteed by design. Tested for 20KHz to 2.0MHz.
5. An overload is that condition with a load in excess of the rated load but less than that necessary to trigger the short circuit protection and is the condition of maximum power dissipation.
6. Above 125°C case temperature, derate output power linearly to 0 at 135°C case

**Block Diagram**

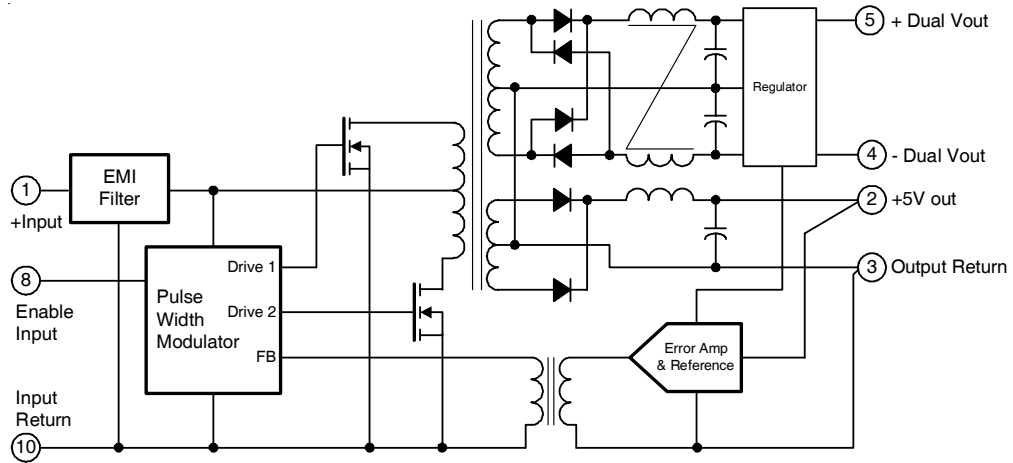

**Standard Microcircuit Drawing Equivalence Table**

Standard Microcircuit Drawing Number	Vendor Cage Code	IR Standard Part Number
5962-90954	52467	ATO2815T
5962-91602	52467	ATO2812T

Mechanical Outlines

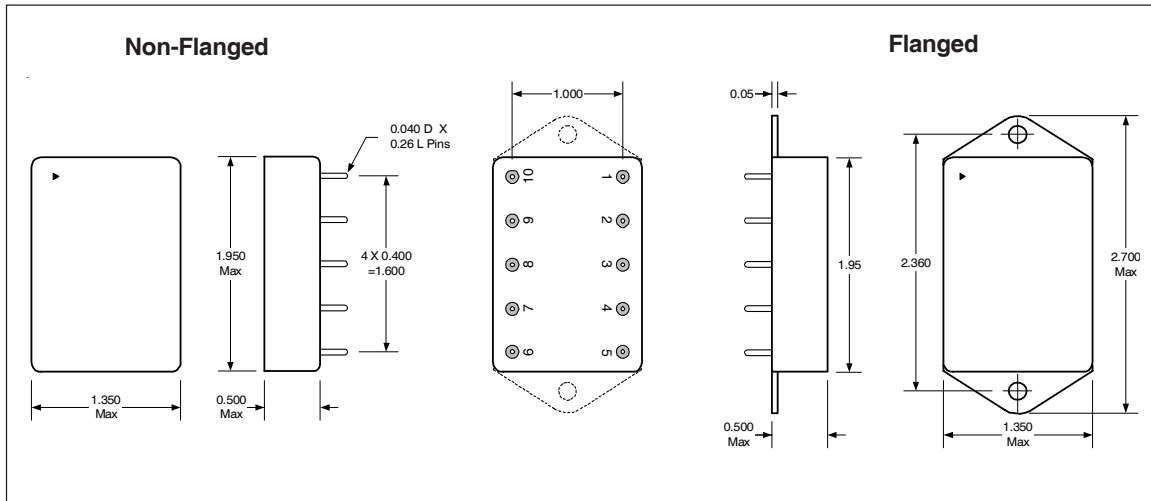

Pin Designation

Pin #	Designation
1	+ Input
2	+5V Output
3	Output Return
4	- Dual Output
5	+ Dual Output
6	NC
7	Case Ground
8	Enable Input
9	NC
10	Input Return

**Device Screening**

Requirement	MIL-STD-883 Method	No Suffix	ES ②	HB	CH
Temperature Range	—	-20°C to +85°C	-55°C to +125°C ③	-55°C to +125°C	-55°C to +125°C
Element Evaluation	MIL-PRF-38534	N/A	N/A	N/A	Class H
Non-Destructive Bond Pull	2023	N/A	N/A	N/A	N/A
Internal Visual	2017	①	Yes	Yes	Yes
Temperature Cycle	1010	N/A	Cond B	Cond C	Cond C
Constant Acceleration	2001, Y1 Axis	N/A	500 Gs	3000 Gs	3000 Gs
PIND	2020	N/A	N/A	N/A	N/A
Burn-In	1015	N/A	48 hrs@hi temp	160 hrs@125°C	160 hrs@125°C
Final Electrical ( Group A )	MIL-PRF-38534 & Specification	25°C	25°C ②	-55°C, +25°C, +125°C	-55°C, +25°C, +125°C
PDA	MIL-PRF-38534	N/A	N/A	N/A	10%
Seal, Fine and Gross	1014	Cond A	Cond A, C	Cond A, C	Cond A, C
Radiographic	2012	N/A	N/A	N/A	N/A
External Visual	2009	①	Yes	Yes	Yes

**Notes:**

- ① Best commercial practice
- ② Sample tests at low and high temperatures
- ③ -55°C to +105°C for AHE, ATO, ATW

**Part Numbering**
