

AFL270XXS Series

28V Input, Single Output

Part Numbers: AFL27005S, AFL27006S, AFL27009S, AFL27012S, AFL27015S, AFL27028S



Advanced Product Brief

The AFL Series of DC/DC converters feature high power density with no derating over the full military temperature range. This series is offered as part of a complete family of converters providing single and dual output voltages and operating from nominal +28V or +270V inputs with output power ranging from 80W to 120W. For applications requiring higher output power, individual converters can be operated in parallel. The internal current sharing circuits assure equal current distribution among the paralleled converters. This series incorporates our proprietary magnetic pulse feedback technology providing optimum dynamic line and load regulation response. This feedback system samples the output voltage at the pulse width modulator fixed clock frequency, nominally 550KHz. Multiple converters can be synchronized to a system clock in the 500KHz to 700KHz range or to the synchronization output of one converter. Undervoltage lockout, primary and secondary referenced inhibit, soft-start and load fault protection are provided on all models.

These converters are hermetically packaged in two enclosure variations, utilizing copper core pins to minimize resistive DC losses. Three lead styles are available, each fabricated with our rugged ceramic lead-to-package seal assuring long term hermeticity in the most-harsh environments.

Manufactured in a facility fully qualified to MIL-PRF-38534, these converters are fabricated utilizing DSCC qualified processes. For available screening options, refer to device screening table in the data sheet. Variations in electrical, mechanical and screening can be accommodated.

Features

- 160V to 400V Input Range
- 5V, 6V, 9V, 12V, 15V and 28V Outputs Available
- High Power Density - up to 84W/in³
- Up to 120W Output Power
- Parallel Operation with Stress and Current Sharing
- Low Profile (0.380") Seam Welded Package
- Ceramic Feed-Thru Copper Core Pins
- High Efficiency - to 87%
- Full Military Temperature Range
- Continuous Short Circuit and Overload Protection
- Primary and Secondary Referenced Inhibit Functions
- Line Rejection > 60dB - DC to 50KHz
- External Synchronization Port
- Fault Tolerant Design
- Dual Output Versions Available
- Standard Microcircuit Drawing Available

Revision History

Revision	Description	Release Date
1.0	AFL270XXS Microcross Datasheet	11/21/2024

Table of Contents

1.0	Specifications	6
2.0	Block Diagram	12
3.0	Circuit Operation and Application Information	12
4.0	Remote Sensing.....	12
5.0	Inhibit Converter Output (Enable)	13
6.0	Synchronization of Multiple Converters	13
7.0	Parallel Operation-Current and Stress Sharing	14
8.0	Thermal Considerations	15
9.0	Input Filter.....	16
10.0	Undervoltage Lockout.....	16
11.0	Output Voltage Adjust	16
12.0	Performance Data	17
13.0	Typical Line Rejection Characteristics	18
14.0	Typical Efficiency Characteristics	19
15.0	AFL27005S Typical Performance Characteristics	20
16.0	AFL27015S Typical Performance Characteristics	21
17.0	AFL27028S Typical Performance Characteristics	22
18.0	Mechanical Outlines	23
19.0	Pin Designation	24
20.0	Standard Microcircuit Drawing Equivalence.....	24
21.0	Device Screening.....	25
22.0	Part Ordering.....	26

List of Figures

Figure 1. AFL Single Output.....	12
Figure 2. Enable Input Equivalent Circuit.....	13
Figure 3. Preferred Connection for Parallel Operation.....	14
Figure 4. Input Filter Circuit	16
Figure 5. Connection for V_{OUT} Adjustment.....	17
Figure 6. Typical Line Rejection - AFL27005S.....	18

Hybrid-High Reliability DC/DC Converter



Figure 7. Typical Line Rejection - AFL27006S.....	18
Figure 8. Typical Line Rejection - AFL27009S.....	18
Figure 9. Typical Line Rejection - AFL27012S.....	18
Figure 10. Typical Line Rejection - AFL27015S.....	18
Figure 11. Typical Line Rejection - AFL27028S.....	18
Figure 12. Typical Efficiency - AFL27005S	19
Figure 13. Typical Efficiency - AFL27006S	19
Figure 14. Typical Efficiency - AFL27009S	19
Figure 15. Typical Efficiency - AFL27012S	19
Figure 16. Typical Efficiency - AFL27015S	19
Figure 17. Typical Efficiency - AFL27028S	19
Figure 18. Turn-On Time, No Load.....	20
Figure 19. Turn-On Time, Full Load.....	20
Figure 20. Output Ripple Voltage.....	20
Figure 21. Input Ripple Current.....	20
Figure 22. Output Load Transient Response 50% Load to/from 100% Load.....	20
Figure 23. Output Load Transient Response 10% Load to/from 50% Load	20
Figure 24. Turn-On Time, No Load.....	21
Figure 25. Turn-On Time, Full Load.....	21
Figure 26. Output Ripple Voltage.....	21
Figure 27. Input Ripple Current.....	21
Figure 28. Output Load Transient Response 50% Load to/from 100% Load	21
Figure 29. Output Load Transient Response 10% Load to/from 50% Load	21
Figure 30. Turn-On Time, No Load.....	22
Figure 31. Turn-On Time, Full Load.....	22
Figure 32. Output Ripple Voltage.....	22
Figure 33. Input Ripple Current.....	22
Figure 34. Output Load Transient Response 50% Load to/from 100% Load	22
Figure 35. Output Load Transient Response 10% Load to/from 50% Load	22
Figure 36. Case X.....	23
Figure 37. Case W.....	23
Figure 38. Case Y	23

Figure 39. Case Z 23

List of Tables

Table 1. Absolute Maximum Ratings 6

Table 2. Static Characteristics 6

Table 3. Dynamic Characteristics 9

Table 5. Pin Designation..... 24

Table 6. SMD Equivalence..... 24

Table 7. Device Screening 25

1.0 Specifications

Table 1. Absolute Maximum Ratings	
Input Voltage	-0.5V to +50VDC
Soldering Temperature	300°C for 10 seconds
Operating Case Temperature	-55°C to +125°C
Storage Case Temperature	-65°C to +135°C

Table 2. Static Characteristics						
-55°C < T _{CASE} ≤ +125°C, 160V ≤ V _{IN} ≤ 400V Unless Otherwise Specified						
Parameter	Group A Subgroups	Test Conditions	Min	Nom	Max	Unit
Input Voltage		Note 6	160	270	400	V
Output Voltage		V _{IN} = 270V, 100% Load				
AFL27005S	1		4.95	5.00	5.05	
AFL27006S	1		5.94	6.00	6.06	
AFL27009S	1		8.91	9.00	9.09	
AFL27012S	1		11.88	12.00	12.12	
AFL27015S	1		14.85	15.00	15.15	
AFL27028S	1		27.72	28.00	28.28	V
AFL27005S	2,3		4.90		5.10	
AFL27006S	2,3		5.88		6.12	
AFL27009S	2,3		8.82		9.18	
AFL27012S	2,3		11.76		12.24	
AFL27015S	2,3		14.70		15.30	
AFL27028S	2,3		27.44		28.56	
Output Current		V _{IN} = 160, 270, 400V. Note 6				
AFL27005S					16.0	
AFL27006S					13.5	
AFL27009S					10.0	A
AFL27012S					9.0	
AFL27015S					8.0	

Table 2. Static Characteristics Cont.

-55°C < T_{CASE} ≤ +125°C, 16V ≤ V_{IN} ≤ 40V Unless Otherwise Specified

Parameter	Group A Subgroups	Test Conditions	Min	Nom	Max	Unit
Output Current AFL27028S		V _{IN} = 160, 270, 400V. Note 6			4.0	A
Output Power AFL27005S AFL27006S AFL27009S AFL27012S AFL27015S AFL27028S		Note 6			80 81 90 108 120 112	W
Maximum Capacitive Load		Note 1	10,000			μF
Output Voltage Temperature Coefficient		V _{IN} = 270V, 100% Load. Notes 1,6	-0.015		+0.015	%/°C
Output Voltage Regulation AFL27028S Line All Others Line Load	1,2,3 1,2,3 1,2,3	No Load, 50% Load, 100% Load V _{IN} = 160, 270, 400V	-70.0 -10.0 -1.0		+70.0 +10.0 +1.0	mV mV %
Output Ripple Voltage AFL27005S AFL27006S AFL27009S AFL27012S AFL27015S AFL27028S	1,2,3 1,2,3 1,2,3 1,2,3 1,2,3 1,2,3	V _{IN} = 160, 270, 400V, 100% Load BW = 10MHz			30 35 40 45 50 100	mVpp
Input Current No Load Inhibit 1	1 2,3 1,2,3	V _{IN} = 270V, 100% Load I _{OUT} = 0 Pin 4 Shortened to Pin 2			15.00 17.00 3.00	mA

Table 2. Static Characteristics Cont.

-55°C < T_{CASE} ≤ +125°C, 16V ≤ V_{IN} ≤ 40V Unless Otherwise Specified

Parameter	Group A Subgroups	Test Conditions	Min	Nom	Max	Unit
Input Current						
Inhibit 2	1,2,3	Pin 12 Shortened to Pin 8			5.00	mA
Input Ripple Current		V _{IN} = 270V, 100% Load BW = 10MHz				
AFL27005S	1,2,3				60	mApp
AFL27006S	1,2,3				60	
AFL27009S	1,2,3				70	
AFL27012S	1,2,3				70	
AFL27015S	1,2,3				80	
AFL27028S	1,2,3				80	
Current Limit Point		V _{OUT} = 90% V _{NOM} . Note 5				
Expressed as Percentage of Full Rated Load	1		115		125	%
	2		105		115	
	3		125		140	
Load Fault Power Dissipation		V _{IN} = 270V				
Overload or Short Circuit	1,2,3				30	W
Efficiency		V _{IN} = 270V, 100% Load				
AFL27005S	1,2,3		78	82		%
AFL27006S	1,2,3		79	83		
AFL27009S	1,2,3		80	84		
AFL27012S	1,2,3		82	85		
AFL27015S	1,2,3		83	87		
AFL27028S	1,2,3		82	85		
Enable Inputs (Inhibit Function)						
Converter Off	1,2,3	Logical Low on Pin 4 or Pin 12	-0.5		0.8	V
Sink Current		Note 1			100	μA

Table 2. Static Characteristics Cont.

-55°C < T_{CASE} ≤ +125°C, 16V ≤ V_{IN} ≤ 40V Unless Otherwise Specified

Parameter	Group A Subgroups	Test Conditions	Min	Nom	Max	Unit
Enable Inputs (Inhibit Function)						
Converter On	1,2,3	Logical High on Pin 4 & 12. Note 9	2.0		50	V
Sink Current		Note 1			100	μA
Switching Frequency	1,2,3		500	550	600	KHz
Synchronization Input						
Frequency Range	1,2,3		500		700	KHz
Pulse Amplitude, Hi	1,2,3		2.0		10	V
Pulse Amplitude, Lo	1,2,3		-0.5		0.8	V
Pulse Rise Time		Note 1			100	ns
Pulse Duty Cycle		Note 1	20		80	%
Isolation	1	Input Output or Any Pin to Case (except Pin 3). Test @ 500VDC	100			MΩ
Device Weight		Slight Variations with Case Style		85		g
MTBF		MIL-HDBK-217F, AIF at T _C = 40°C	300			KHrs

Table 3. Dynamic Characteristics

-55°C < T_{CASE} ≤ +125°C, V_{IN} = 270V Unless Otherwise Specified

Parameter	Group A Subgroups	Test Conditions	Min	Nom	Max	Unit
Load Transient Response		Notes 2,8				
AFL27005S Amplitude	4,5,6	Load Step 50% ↔ 100%	-450		450	mV
Recovery	4,5,6				200	μs
Amplitude	4,5,6	Load Step 10% ↔ 50%	-450		450	mV
Recovery	4,5,6				400	μs
AFL27006S Amplitude	4,5,6	Load Step 50% ↔ 100%	-500		450	mV
Recovery	4,5,6				200	μs
Amplitude	4,5,6	Load Step 10% ↔ 50%	-500		450	mV
Recovery	4,5,6				400	μs

Table 3. Dynamic Characteristics Cont.

-55°C < T_{CASE} ≤ +125°C, V_{IN} = 270V Unless Otherwise Specified

Parameter	Group A Subgroups	Test Conditions	Min	Nom	Max	Unit
Load Transient Response						
AFL27009S	Amplitude	4,5,6	Notes 2,8 Load Step 50% ↔ 100%	-600		600 mV
	Recovery	4,5,6				200 μs
	Amplitude	4,5,6	Load Step 10% ↔ 50%	-600		600 mV
	Recovery	4,5,6				400 μs
AFL27012S	Amplitude	4,5,6	Load Step 50% ↔ 100%	-750		750 mV
	Recovery	4,5,6				200 μs
	Amplitude	4,5,6	Load Step 10% ↔ 50%	-750		750 mV
	Recovery	4,5,6				400 μs
AFL27015S	Amplitude	4,5,6	Load Step 50% ↔ 100%	-900		900 mV
	Recovery	4,5,6				200 μs
	Amplitude	4,5,6	Load Step 10% ↔ 50%	-900		900 mV
	Recovery	4,5,6				400 μs
AFL27028S	Amplitude	4,5,6	Load Step 50% ↔ 100%	-1200		1200 mV
	Recovery	4,5,6				200 μs
	Amplitude	4,5,6	Load Step 10% ↔ 50%	-1200		1200 mV
	Recovery	4,5,6				400 μs
Line Transient Response						
	Amplitude		Notes 1,2,3 V _{IN} Step = 160 ↔ 400V	-500		500 mV
	Recovery					500 μs
Turn-On Characteristics						
	Overshoot	4,5,6	V _{IN} = 160, 270, 400V. Note 4 Enable 1,2 on. (Pins 4, 12 high or open)			250 mV
	Delay	4,5,6		50	75	120 ms
Load Fault Recovery						
			Same as Turn-On Characteristics			
Line Rejection						
			MIL-STD-461, CS101, 30Hz to 50KHz – Note 1	60	70	dB

Notes to Specifications:

1. Parameters not 100% tested but are guaranteed to the limits specified in the table.
2. Recovery time is measured from the initiation of the transient to where V_{OUT} has returned to within $\pm 1.0\%$ of V_{OUT} at 50% load.
3. Line transient transition time $\geq 100\mu s$.
4. Turn-on delay is measured with an input voltage rise time of between 100V and 500V per millisecond.
5. Current limit point is that condition of excess load causing output voltage to drop to 90% of nominal.
6. Parameter verified as part of another test.
7. All electrical tests are performed with the remote sense leads connected to the output leads at the load.
8. Load transient transition time $\geq 10\mu s$.
9. Enable inputs internally pulled high. Nominal open circuit voltage $\approx 4.0VDC$.

2.0 Block Diagram

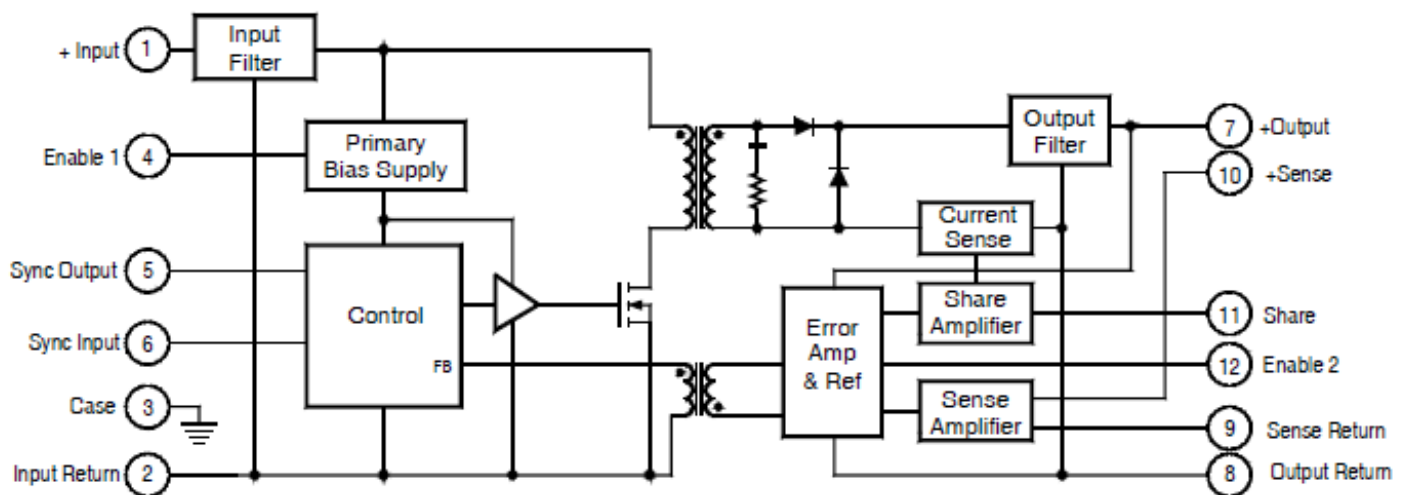

Figure 1. AFL Single Output

3.0 Circuit Operation and Application Information

The AFL series of converters employ a forward switched mode converter topology. (refer to Figure 1.) Operation of the device is initiated when a DC voltage whose magnitude is within the specified input limits is applied between pins 1 and 2. If pin 4 is enabled (at a logical 1 or open) the primary bias supply will begin generating a regulated housekeeping voltage bringing the circuitry on the primary side of the converter to life. Two power MOSFETs used to chop the DC input voltage into a high frequency square wave, apply this chopped voltage to the power transformer. As this switching is initiated, a voltage is impressed on a second winding of the power transformer which is then rectified and applied to the primary bias supply. When this occurs, the input voltage is shut out and the primary bias voltage becomes exclusively internally generated.

The switched voltage impressed on the secondary output transformer winding is rectified and filtered to provide the converter output voltage. An error amplifier on the secondary side compares the output voltage to a precision reference and generates an error signal proportional to the difference. This error signal is magnetically coupled through the feedback transformer into the controller section of the converter varying the pulse width of the square wave signal driving the MOSFETs, narrowing the width if the output voltage is too high and widening it if it is too low.

4.0 Remote Sensing

Connection of the + and - sense leads at a remotely located load permits compensation for excessive resistance between the converter output and the load when their physical separation could cause undesirable voltage drop. This connection allows regulation to the placard voltage at the point of application. When the remote sensing feature is not used, the sense should be connected to their respective output terminals at the converter. Figure 3. illustrates a typical remotely sensed application.

5.0 Inhibit Converter Output (Enable)

As an alternative to application and removal of the DC voltage to the input, the user can control the converter output by providing TTL compatible, positive logic signals to either of two enable pins (pin 4 or 12). The distinction between these two signal ports is that enable 1 (pin 4) is referenced to the input return (pin 2) while enable 2 (pin 12) is referenced to the output return (pin 8). Thus, the user has access to an inhibit function on either side of the isolation barrier. Each port is internally pulled “high” so that when not used, an open connection on both enable pins permits normal converter operation. When their use is desired, a logical “low” on either port will shut the converter down.

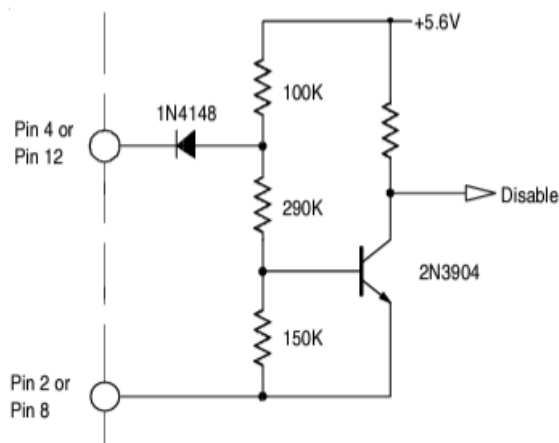

Figure 2. Enable Input Equivalent Circuit

Internally, these ports differ slightly in their function. In use, a low on Enable 1 completely shuts down all circuits in the converter while a low on Enable 2 shuts down the secondary side while altering the controller duty cycle to near zero. Externally, the use of either port is transparent to the user save for minor differences in idle current. (See specification table).

6.0 Synchronization of Multiple Converters

When operating multiple converters, system requirements often dictate operation of the converters at a common frequency. To accommodate this requirement, the AFL series converters provide both a synchronization input and output.

The sync input port permits synchronization of an AFL converter to any compatible external frequency source operating between 500KHz and 700KHz. This input signal should be referenced to the input return and have a 10% to 90% duty cycle. Compatibility requires transition times less than 100ns, maximum low level of +0.8V and a minimum high level of +2.0V. The sync output of another converter which has been designated as the master oscillator provides a convenient frequency source for this mode of operation. When external synchronization is not required, the sync in pin should be left unconnected thereby permitting the converter to operate at its' own internally set frequency.

The sync output signal is a continuous pulse train set at $550 \pm 50\text{KHz}$, with a duty cycle of $15 \pm 5.0\%$. This signal is referenced to the input return and has been tailored to be compatible with the AFL sync input port. Transition times are less than 100ns and the low-level output impedance is less than 50Ω . This signal is active when the DC input voltage is within the specified operating range and the converter is not inhibited. This output has adequate drive reserve to synchronize at least five additional converters. A typical synchronization connection option is illustrated in Figure 3.

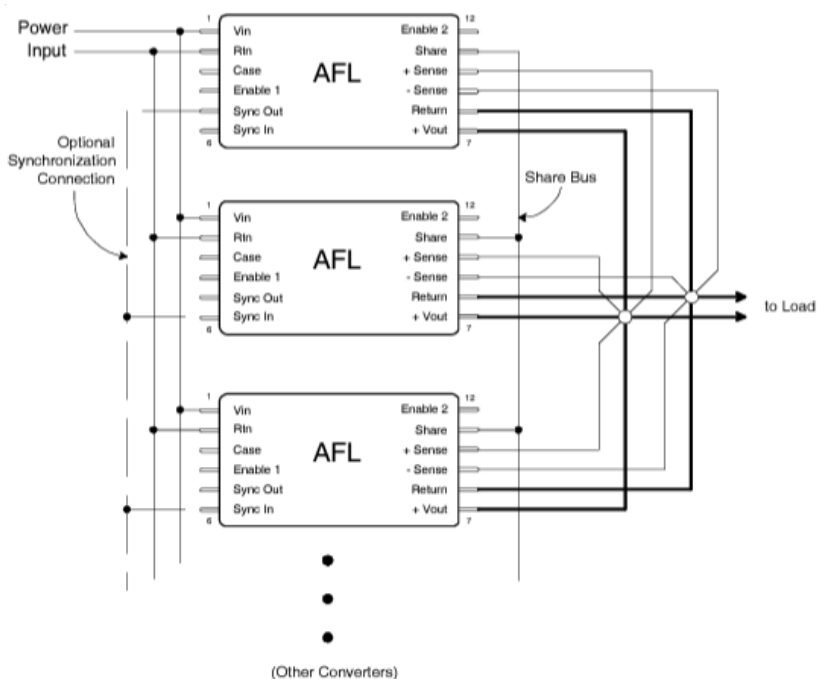

Figure 3. Preferred Connection for Parallel Operation

7.0 Parallel Operation-Current and Stress Sharing

Figure 3. illustrates the preferred connection scheme for operation of a set of AFL converters with outputs operating in parallel. Use of this connection permits equal current sharing among the members of a set whose load current exceeds the capacity of an individual AFL. An important feature of the AFL series operating in the parallel mode is that in addition to sharing the current, the stress induced by temperature will also be shared. Thus, if one member of a paralleled set is operating at a higher case temperature, the current it provides to the load will be reduced as compensation for the temperature induced stress on that device.

When operating in the shared mode, it is important that symmetry of connection be maintained as an assurance of optimum load sharing performance. Thus, converter outputs should be connected to the load with equal lengths of wire of the same gauge and should be connected to a common physical point, preferably at the load along with the converter output and return leads. All converters in a paralleled set must have their share pins connected together. This arrangement is diagrammatically illustrated in Figure 3. showing the output and return pins connected at a star point which is located close as possible to the load.

As a consequence of the topology utilized in the current sharing circuit, the share pin may be used for other functions. In applications requiring only a single converter, the voltage appearing on the share pin may be used as a “total current monitor”. The share pin open circuit voltage is nominally +1.00V at no load and increases linearly with increasing total output current to +2.20V at full load. Note that the current we refer to here is the total output current, that is, the sum of the positive and negative output currents.

8.0 Thermal Considerations

Because of the incorporation of many innovative technological concepts, the AFL series of converters is capable of providing very high output power from a package of very small volume. These magnitudes of power density can only be obtained by combining high circuit efficiency with effective methods of heat removal from the die junctions. This requirement has been effectively addressed inside the device; but when operating at maximum loads, a significant amount of heat will be generated and this heat must be conducted away from the case. To maintain the case temperature at or below the specified maximum of 125°C, this heat must be transferred by conduction to an appropriate heat dissipater held in intimate contact with the converter base-plate.

Because effectiveness of this heat transfer is dependent on the intimacy of the baseplate/heatsink interface, it is strongly recommended that a high thermal conductivity heat transference medium is inserted between the baseplate and heatsink. The material most frequently utilized at the factory during all testing and burn-in processes is sold under the trade name of Sil-Pad[®] 400¹. This particular product is an insulator but electrically conductive versions are also available. Use of these materials assures maximum surface contact with the heat dissipator thereby compensating for minor variations of either surface. While other available types of heat conductive materials and compounds may provide similar performance, these alternatives are often less convenient and are frequently messy to use.

¹Sil-Pad is a registered Trade Mark of Bergquist, Minneapolis, MN.

A conservative aid to estimating the total heat sink surface area ($A_{HEAT\ SINK}$) required to set the maximum case temperature rise (ΔT) above ambient temperature is given by the following expression:

$$A_{HEATSINK} \approx \left\{ \frac{\Delta T}{80P^{0.85}} \right\}^{-1.43} - 3.0$$

Where

ΔT = Case temperature rise above ambient

P = Device dissipation in Watts = $P_{OUT} \left\{ \frac{1}{Eff} - 1 \right\}$

As an example, it is desired to maintain the case temperature of an AFL27015S at $\leq +85^{\circ}\text{C}$ in an area where the ambient temperature is held at a constant $+25^{\circ}\text{C}$; then

$$\Delta T = 85 - 25 = 60^{\circ}\text{C}$$

From the Specification Table, the worst-case full load efficiency for this device is 83%; therefore, the power dissipation at full load is given by

$$P = 120 \cdot \left\{ \frac{1}{.83} - 1 \right\} = 120 \cdot (0.205) = 24.6W$$

And the required heat sink area is

$$A_{HEATSINK} = \left\{ \frac{60}{80 \cdot 24.6^{0.85}} \right\}^{-1.43} - 3.0 = 71in^2$$

Thus, a total heat sink surface area (including fins, if any) of 71in² in this example, would limit case rise to 60°C above ambient. A flat aluminum plate, 0.25" thick and of approximate dimension 4" by 9" (36in² per side) would suffice for this application in a still air environment. Note that to meet the criteria in this example, both sides of the plate require unrestricted exposure to the ambient air.

9.0 Input Filter

The AFL270XXS series converters incorporate a single stage LC input filter whose elements dominate the input load impedance characteristic during the turn-on sequence. The input circuit is as shown in Figure 4.

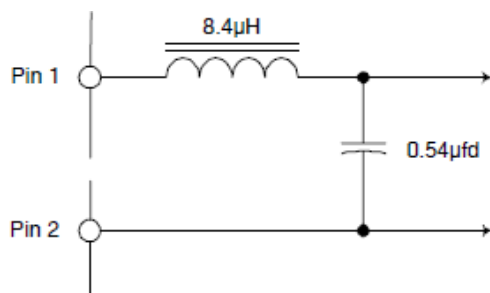

Figure 4. Input Filter Circuit

10.0 Undervoltage Lockout

A minimum voltage is required at the input of the converter to initiate operation. This voltage is set to 150V ± 5.0V. To preclude the possibility of noise or other variations at the input falsely initiating and halting converter operation, a hysteresis of approximately 10V is incorporated in this circuit. Thus, if the input voltage droops to 140V ± 5.0V, the converter will shut down and remain inoperative until the input voltage returns to ≈ 150V.

11.0 Output Voltage Adjust

In addition to permitting close voltage regulation of remotely located loads, it is possible to utilize the converter sense pins to incrementally increase the output voltage over a limited range. The adjustments made possible by this method are intended as a means to “trim” the output to a voltage setting for some particular application, but are not intended to create an adjustable output converter. These output voltage setting variations are obtained by connecting an appropriate resistor value between the +sense and -sense pins while

connecting the -sense pin to the output return pin as shown in Figure 5. below. The range of adjustment and corresponding range of resistance values can be determined by use of the equation presented below.

$$R_{adj} = 100 \cdot \left\{ \frac{V_{NOM}}{V_{OUT} - V_{NOM} - .025} \right\}$$

Where

V_{NOM} = device nominal output voltage, and

V_{OUT} = desired output voltage

Finding a resistor value for a particular output voltage, is simply a matter of substituting the desired output voltage and the nominal device voltage into the equation and solving for the corresponding resistor value.

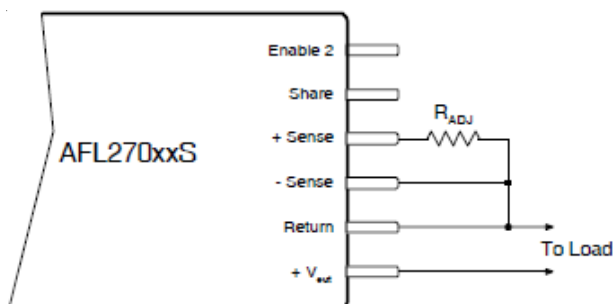

Figure 5. Connection for V_{OUT} Adjustment

Caution: Do not set $R_{adj} < 500\Omega$

Attempts to adjust the output voltage to a value greater than 120% of nominal should be avoided because of the potential of exceeding internal component stress ratings and subsequent operation to failure. Under no circumstance should the external setting resistor be made less than 500Ω. By remaining within this specified range of values, completely safe operation fully within normal component derating is assured. Examination of the equation relating output voltage and resistor value reveals a special benefit of the circuit topology utilized for remote sensing of output voltage in the AFL270XXS series of converters. It is apparent that as the resistance increases, the output voltage approaches the nominal set value of the device. In fact, the calculated limiting value of output voltage as the adjusting resistor becomes very large is $\cong 25\text{mV}$ above nominal device voltage. The consequence is that if the +sense connection is unintentionally broken, an AFL270XXS has a fail-safe output voltage of $V_{OUT} + 25\text{mV}$, where the 25mV is independent of the nominal output voltage. It can be further demonstrated that in the event of both the + and - sense connections being broken; the output will be limited to $V_{OUT} + 440\text{mV}$. This 440mV is also essentially constant independent of the nominal output voltage. While operation in this condition is not damaging to the device, not all performance parameters will be met.

12.0 Performance Data

Typical performance data is graphically presented on the following pages for selected parameters on a variety of AFL270XXS type converters. The data presented was selected as representative of more critical parameters and for general interest in typical converter applications.

13.0 Typical Line Rejection Characteristics

Measured per MIL-STD 461D, CS101 with 100% Output Load, $V_{IN} = 270VDC$

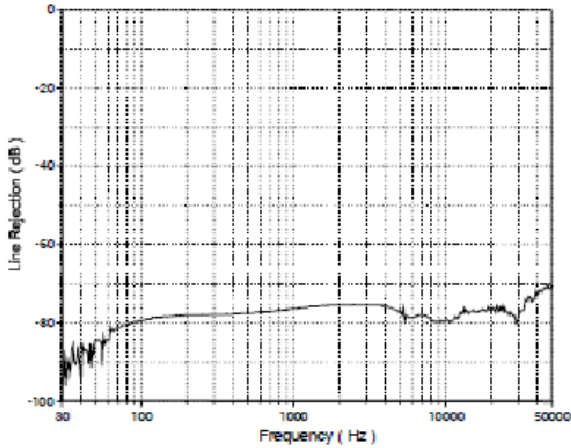

Figure 6. Typical Line Rejection - AFL27005S

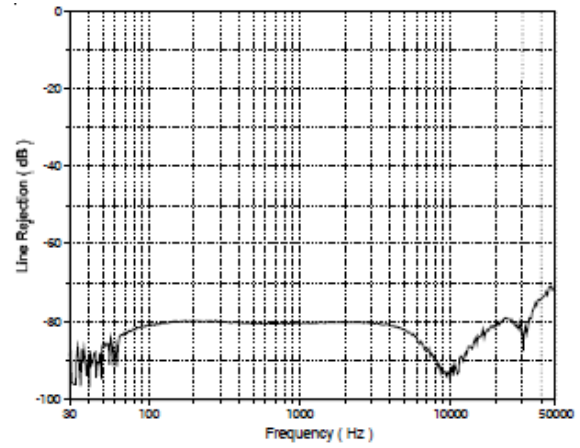

Figure 7. Typical Line Rejection - AFL27006S

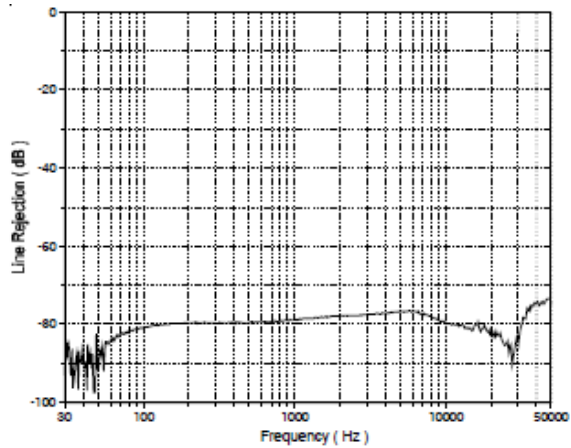

Figure 8. Typical Line Rejection - AFL27009S

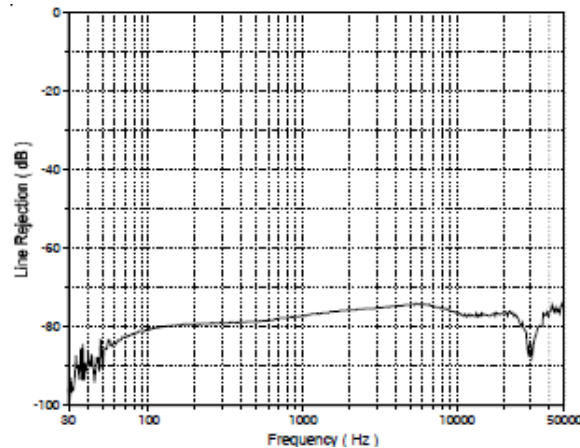

Figure 9. Typical Line Rejection - AFL27012S

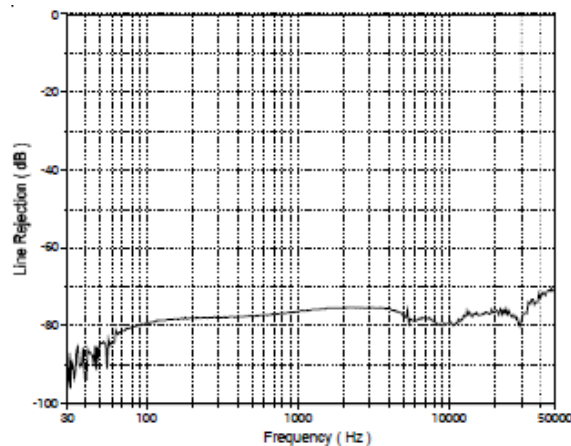

Figure 10. Typical Line Rejection - AFL27015S

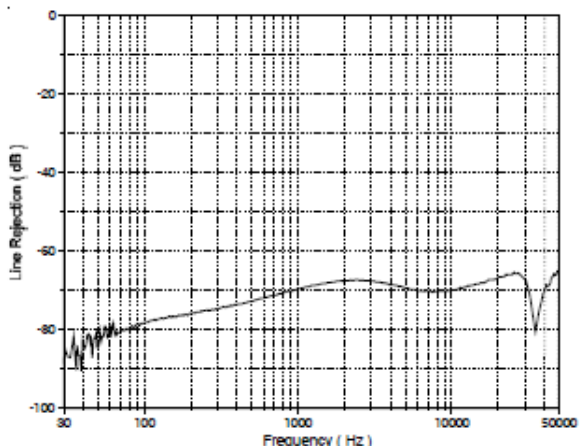

Figure 11. Typical Line Rejection - AFL27028S

14.0 Typical Efficiency Characteristics

Presented for three values of input voltage

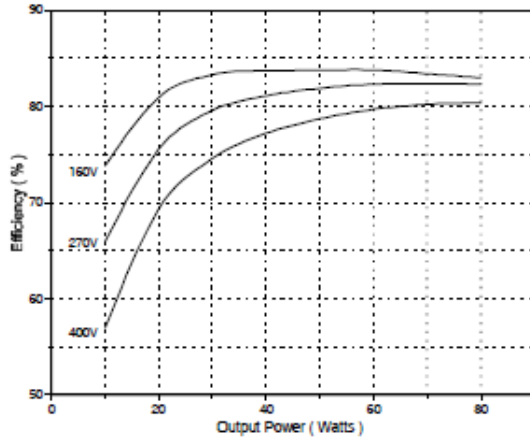

Figure 12. Typical Efficiency - AFL27005S

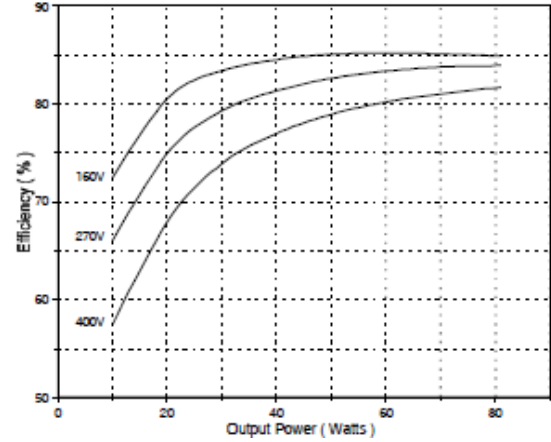

Figure 13. Typical Efficiency - AFL27006S

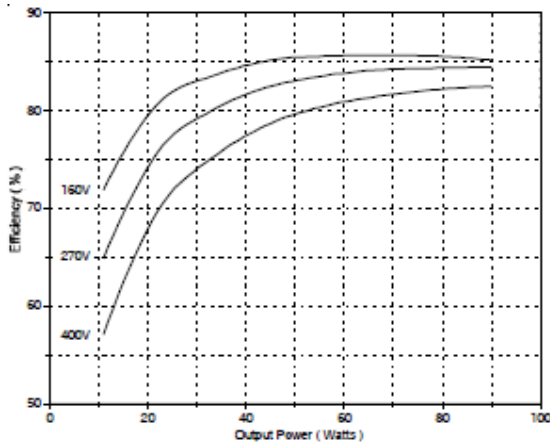

Figure 14. Typical Efficiency - AFL27009S

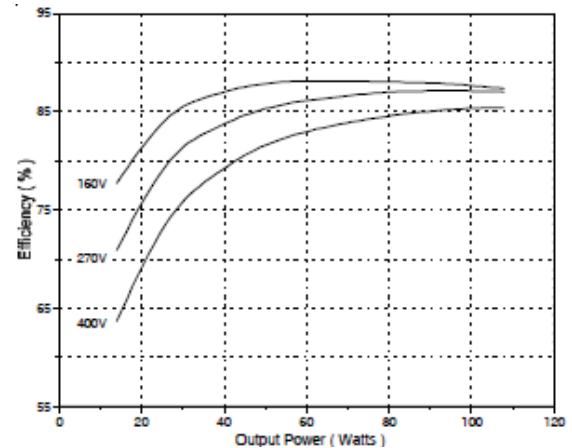

Figure 15. Typical Efficiency - AFL27012S

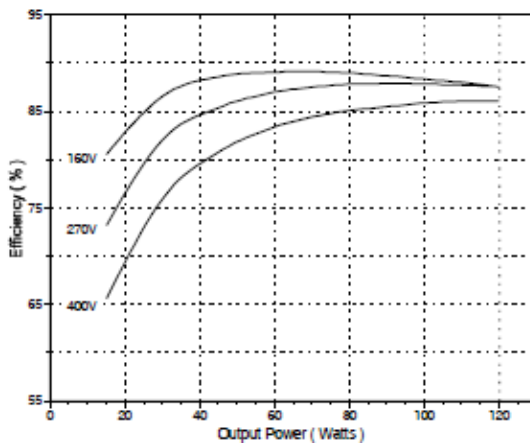

Figure 16. Typical Efficiency - AFL27015S

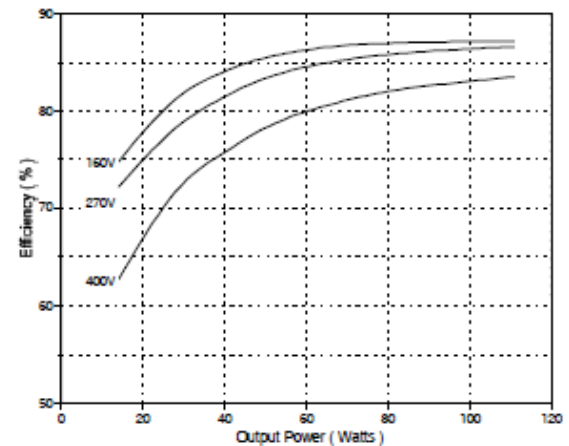

Figure 17. Typical Efficiency - AFL27028S

15.0 AFL27005S Typical Performance Characteristics

Output load = 100%, $V_{IN} = 270VDC$ unless otherwise specified

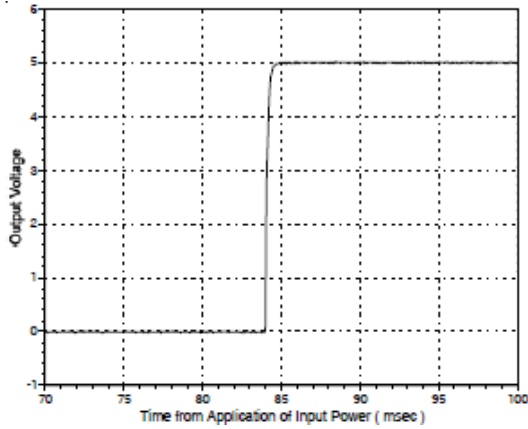

Figure 18. Turn-On Time, No Load

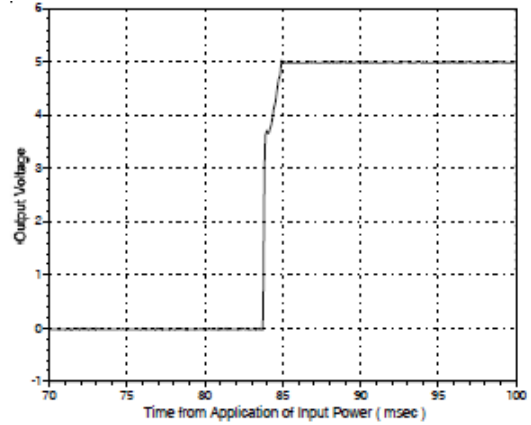

Figure 19. Turn-On Time, Full Load

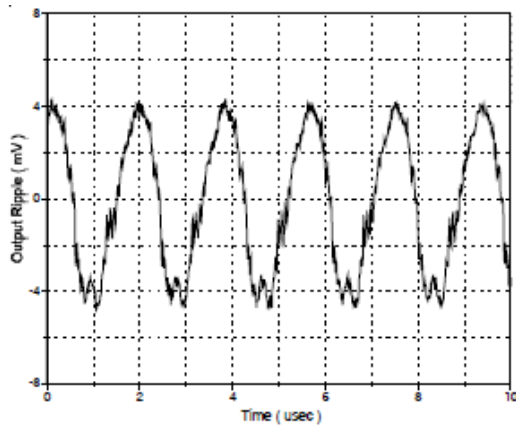

Figure 20. Output Ripple Voltage

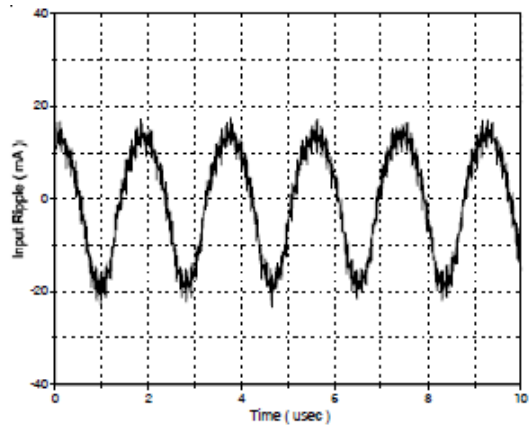

Figure 21. Input Ripple Current

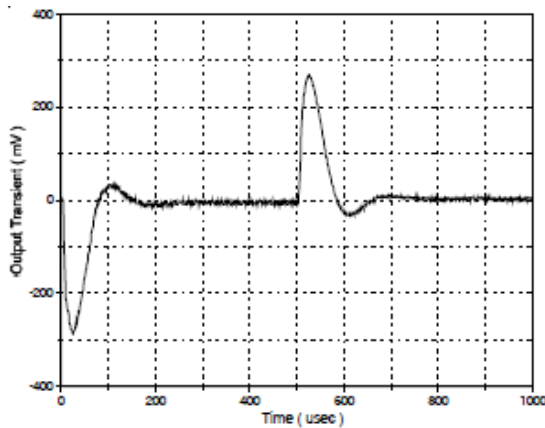

Figure 22. Output Load Transient Response 50% Load to/from 100% Load

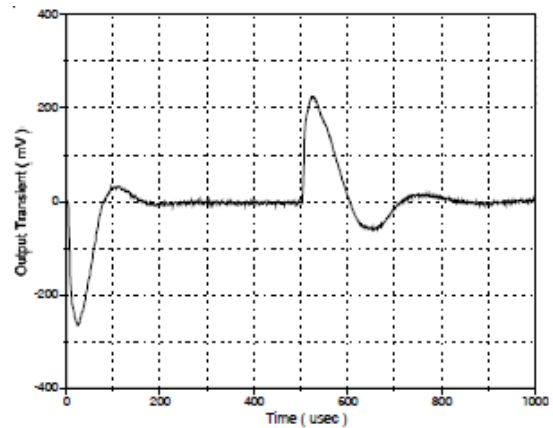

Figure 23. Output Load Transient Response 10% Load to/from 50% Load

16.0 AFL27015S Typical Performance Characteristics

Output load = 100%, $V_{IN} = 270VDC$ unless otherwise specified

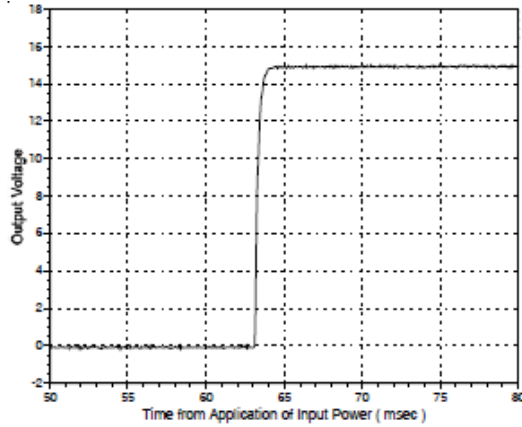

Figure 24. Turn-On Time, No Load

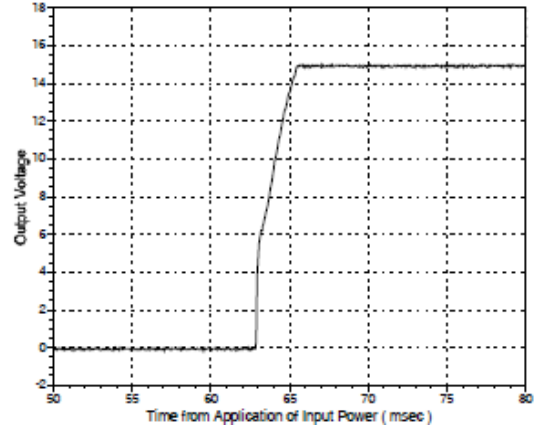

Figure 25. Turn-On Time, Full Load

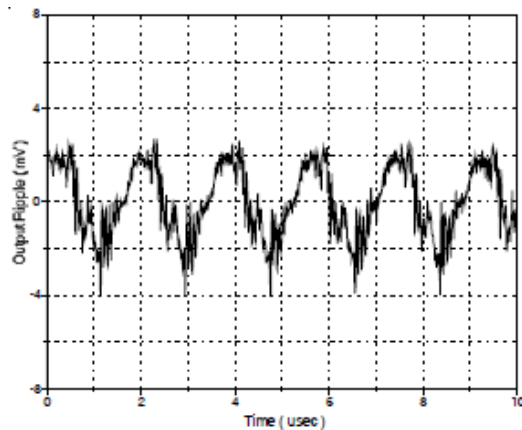

Figure 26. Output Ripple Voltage

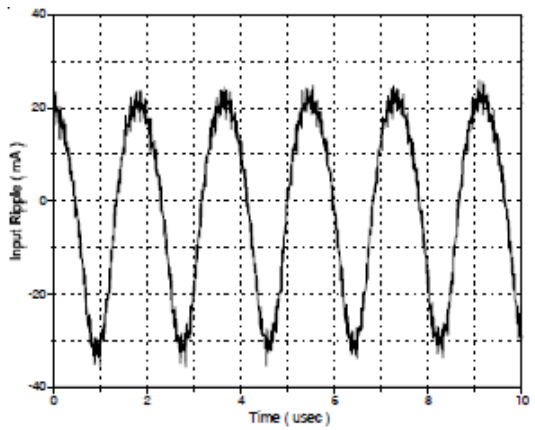

Figure 27. Input Ripple Current

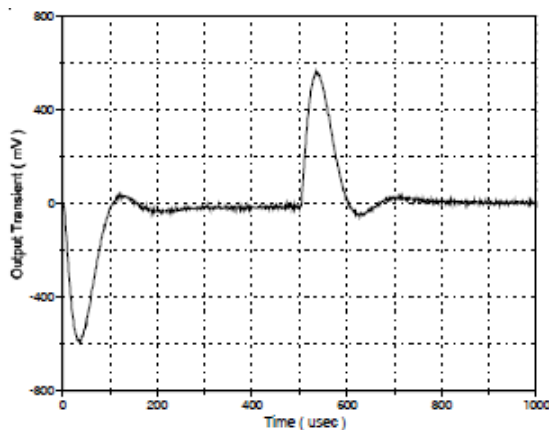

Figure 28. Output Load Transient Response 50% Load to/from 100% Load

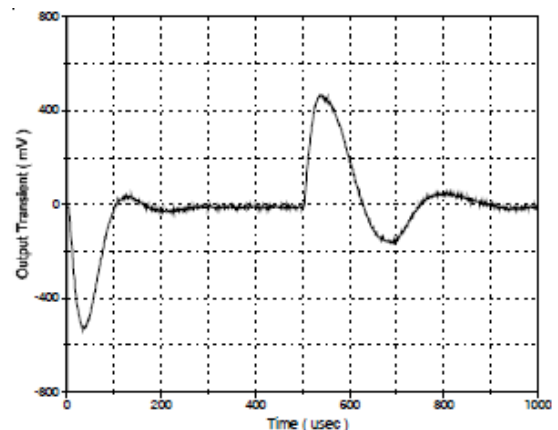

Figure 29. Output Load Transient Response 10% Load to/from 50% Load

17.0 AFL27028S Typical Performance Characteristics

Output load = 100%, $V_{IN} = 270VDC$ unless otherwise specified

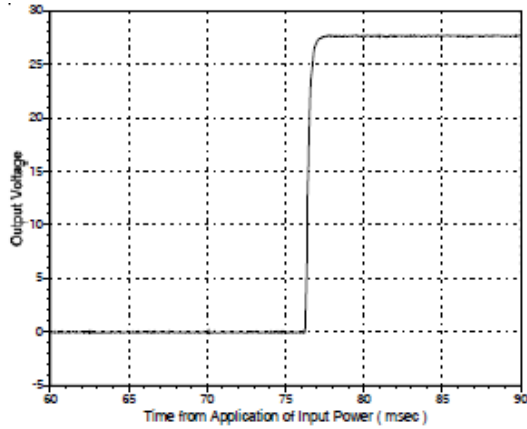

Figure 30. Turn-On Time, No Load

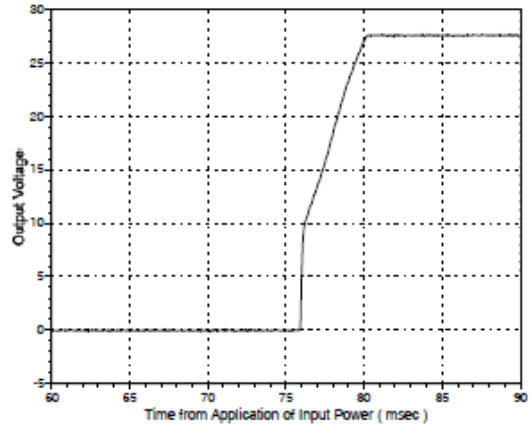

Figure 31. Turn-On Time, Full Load

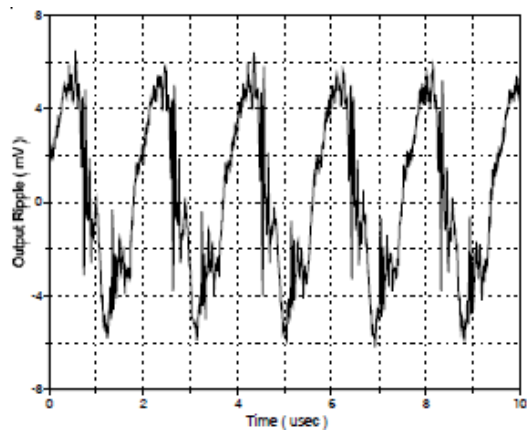

Figure 32. Output Ripple Voltage

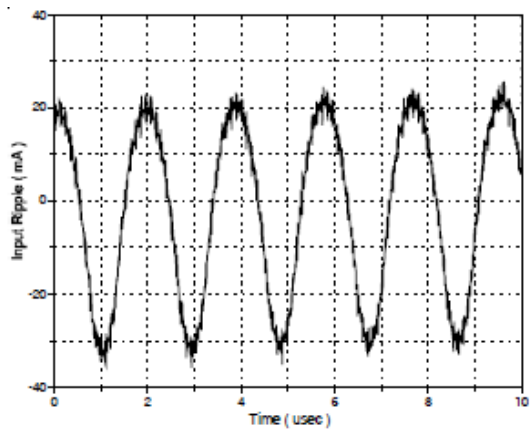

Figure 33. Input Ripple Current

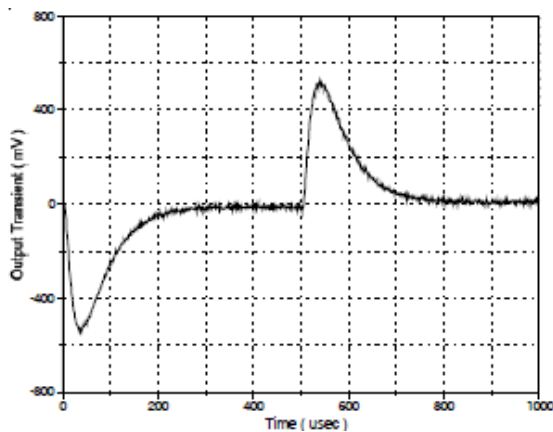

Figure 34. Output Load Transient Response 50% Load to/from 100% Load

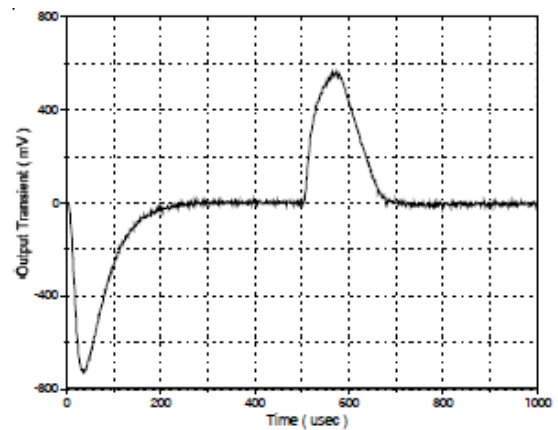

Figure 35. Output Load Transient Response 10% Load to/from 50% Load

18.0 Mechanical Outlines

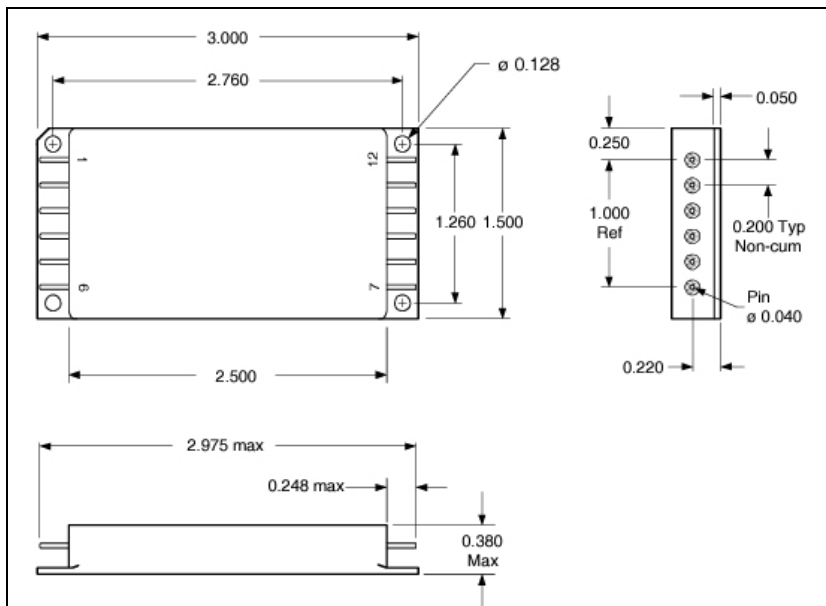

Figure 36. Case X

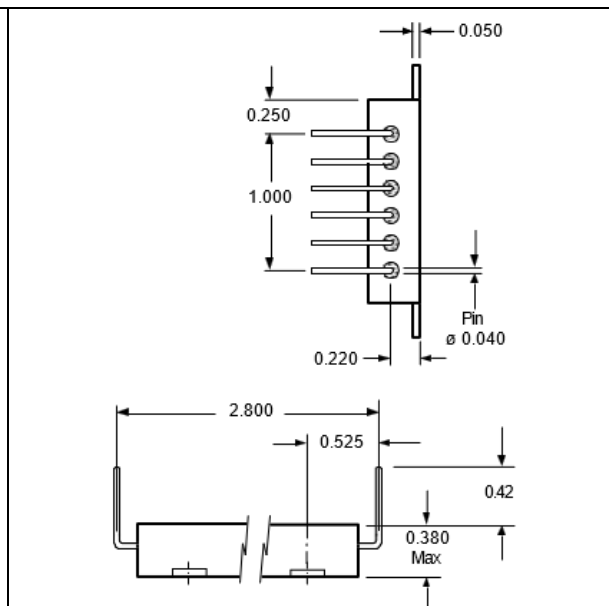

Figure 37. Case W

Pin Variation of Case Y

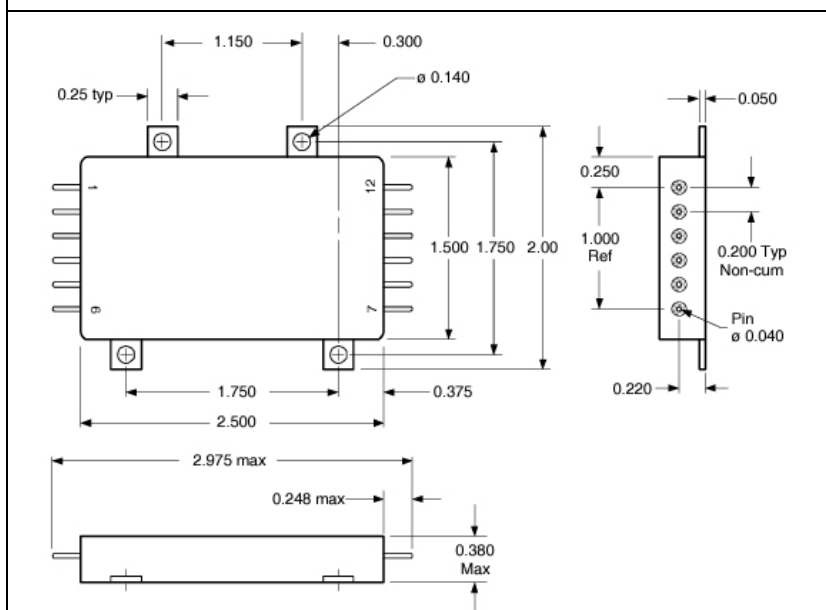

Figure 38. Case Y

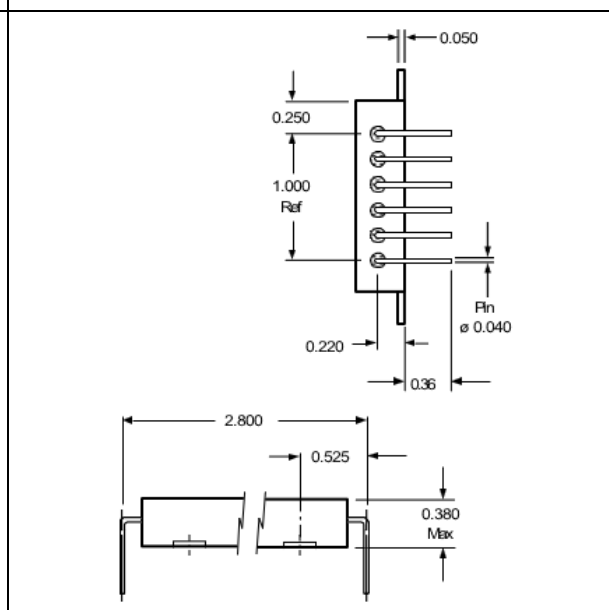

Figure 39. Case Z

Pin Variation of Case Y

Tolerances, unless otherwise specified: .XX = ±0.10

.XXX = ±0.005

BERYLLIA WARNING: These converters are hermetically sealed; however, they contain BeO substrates and should not be ground or subjected to any other operations including exposure to acids, which may produce Beryllium dust or fumes containing Beryllium

19.0 Pin Designation

Table 4. Pin Designation			
Pin #	Designation	Pin #	Designation
1	+ Input	7	+ Output
2	Input Return	8	Output Return
3	Case Ground	9	Sense Return
4	Enable 1	10	+ Sense
5	Sync Output	11	Share
6	Sync Input	12	Enable 2

20.0 Standard Microcircuit Drawing Equivalence

Table 5. SMD Equivalence	
SMD Number	Part Number
5962-94569	AFL27005S
5962-95534	AFL27006S
5962-95535	AFL27009S
5962-94753	AFL27012S
5962-94570	AFL27015S
5962-95565	AFL27028S

21.0 Device Screening

Table 6. Device Screening					
Requirement	MIL-STD-883 Method	No Suffix	ES – Note 2	HB	CH
Temperature Range	–	-20°C to +85°C	-55°C to +125°C – Note 3	-55°C to +125°C	-55°C to +125°C
Element Evaluation	MIL-PRF-38534	N/A	N/A	N/A	Class H
Non-Destructive Bond Pull	2023	N/A	N/A	N/A	N/A
Internal Visual	2017	Note 1	Yes	Yes	Yes
Temperature Cycle	1010	N/A	Cond B	Cond C	Cond C
Constant Acceleration	2001, Y1 Axis	N/A	500Gs	3000Gs	3000Gs
PIND	2020	N/A	N/A	N/A	N/A
Burn-In	1015	N/A	48hrs at Hi Temp	160hrs at 125°C	160hrs at 125°C
Final Electrical (Group A)	MIL-PRF-38534 & Specification	25°C	25°C – Note 2	-55°C, +25°C, +125°C	-55°C, +25°C, +125°C
PDA	MIL-PRF-38534	N/A	N/A	N/A	10%
Seal, Fine and Gross	1014	Cond A	Cond A,C	Cond A,C	Cond A,C
Radiographic	2012	N/A	N/A	N/A	N/A
External Visual	2009	Note 1	Yes	Yes	Yes

Notes:

1. Best commercial practice
2. Sample tests at low and high temperature
3. -55°C to +105°C for AHE, ATO, ATW

22.0 Part Ordering

