

**QUICK REFERENCE  
DATA**

- $V_R = 50V - 1000V$
- $I_F = 120A$
- $t_{rr} = 150nS$
- $I_{FSM} = 1800A$

**HIGH CURRENT, HIGH DENSITY, FAST RECOVERY  
SILICON POWER RECTIFIER STUD**

- Low thermal impedance
- Low forward voltage drop
- Low reverse recovery time
- Low reverse leakage current
- High forward and surge currents ratings

3

**ABSOLUTE MAXIMUM RATINGS**

Device Type*	Working Reverse Voltage ( $V_{RWM}$ ) Volts	Average Rectified Current $I_{F(AV)}$					1 Cycle Surge Current $I_{FSM}$ $t_p = 8.3mS$		Repetitive Surge Current $I_{FRM}$ Amps
		insert mounting			stud mounted	stud + insert	@ 25 °C	@ 100 °C	
		@ 25 °C	@ 55 °C	@ 100 °C	@ 55 °C	@ 55 °C	Amps	Amps	
SCSF05	50	120	100	65	82.5	150	1800	1200	250
SCSF1	100	120	100	65	82.5	150	1800	1200	250
SCSF2	200	120	100	65	82.5	150	1800	1200	250
SCSF4	400	120	100	65	82.5	150	1800	1200	250
SCSF0	1000	85	70	50	60	105	1250	875	150

Normal polarity is cathode to stud

\* add suffix "R" to part number for reverse polarity

**MECHANICAL**

**Maximum thermal impedances**

Stud mounted  $R_{\theta JC} < 0.67^{\circ}C/W$

Insert mounted  $R_{\theta JC} < 0.5^{\circ}C/W$

Stud + insert mtd  $R_{\theta JC} < 0.28^{\circ}C/W$

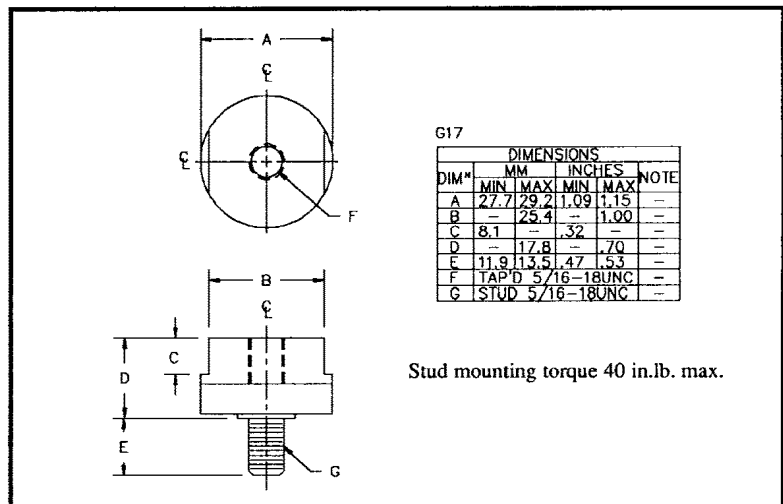

**ELECTRICAL CHARACTERISTICS**

Device Type	Maximum Reverse Leakage Current $I_R @ V_{RWM}$		Forward voltage $V_F @ 100A.$	Reverse Recovery Time <sup>(1)</sup>
	@ 25 °C	@ 100 °C	Max @ 25°C	max @ 25 °C
	µA	µA	Volts	nS
SCSF05	12.0	300	1.35	150
SCSF1	12.0	300	1.35	150
SCSF2	12.0	300	1.35	150
SCSF4	12.0	300	1.35	150
SCSF0	12.0	300	2.0	150

1) Measured on discrete devices prior to assembly.

Operating temperature range    -55 °C to +150 °C  
Storage temperature range        -55 °C to +150 °C

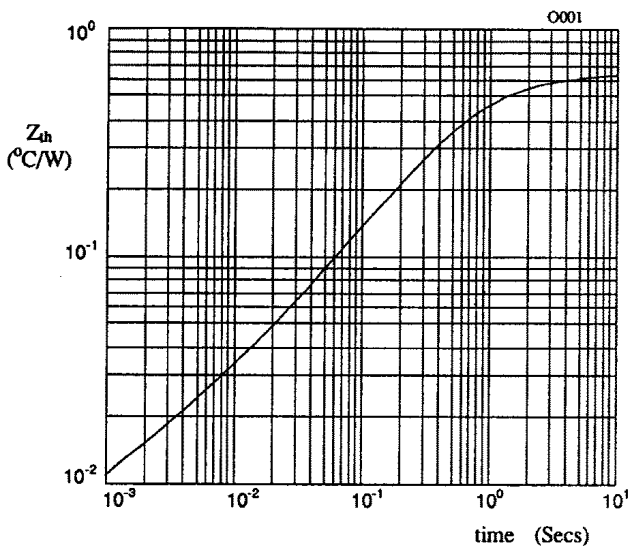

Fig 1. Transient thermal impedance characteristic when stud mounted.

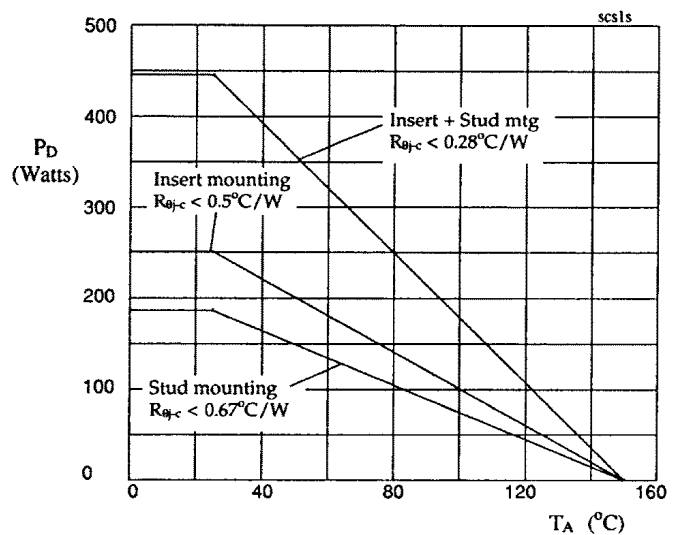

Fig 2. Power dissipation as a function of ambient temperature for different mountings.



3

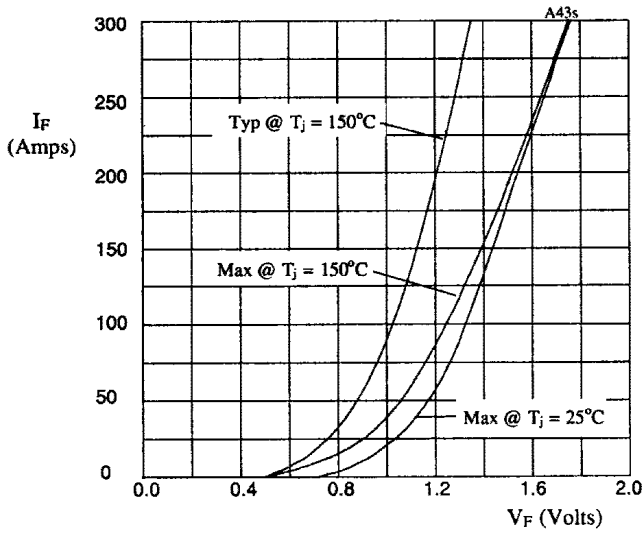

Fig 2. Forward voltage drop as a function of forward current for SCSF05 thru SCSF4.

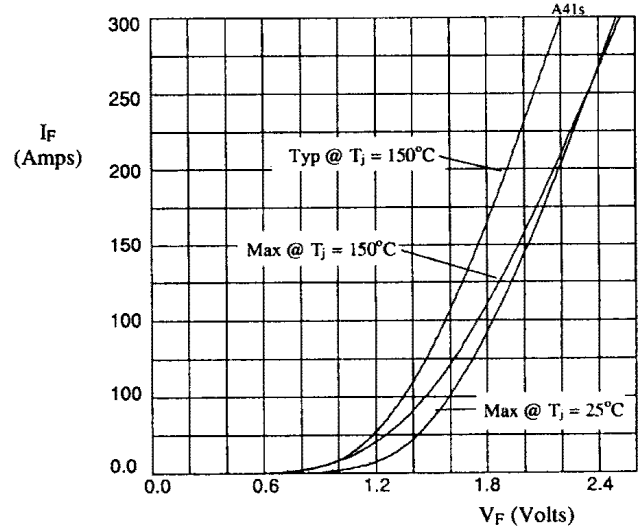

Fig 3. Forward voltage drop as a function of forward current for SCSF0.

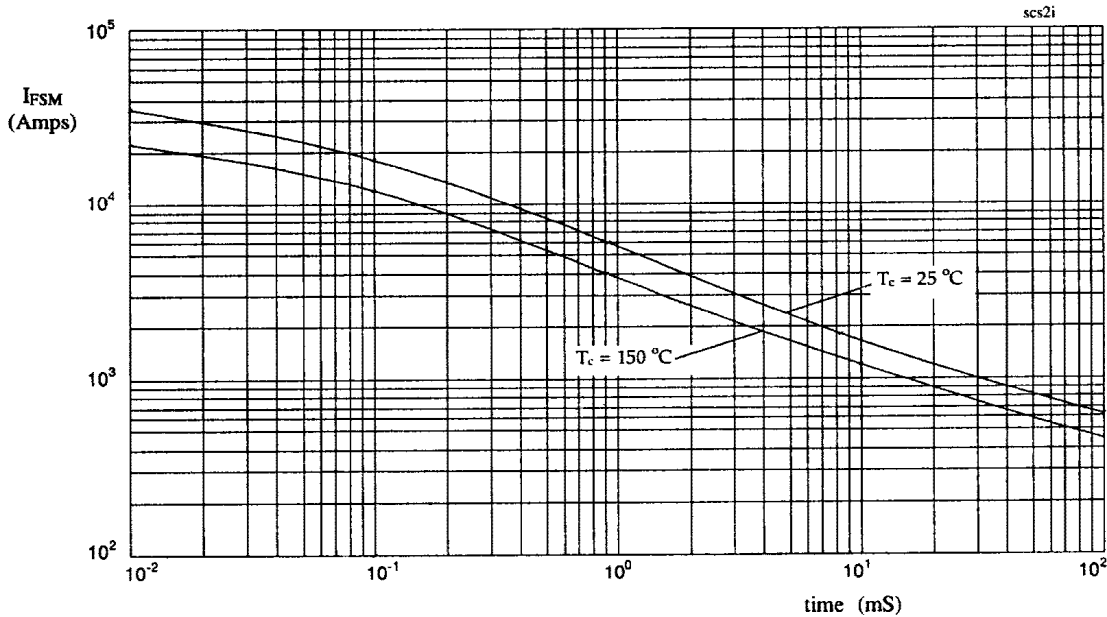

Figure 4. Maximum non-repetitive surge current against pulse width (SCSF05 thru SCSF4).