



Micross MAHB converters offer state of the art noise performance and is specifically designed for noise sensitive RF applications. The MAHB provides excellent input to output noise suppression and the individually regulated outputs eliminates cross regulation & noise coupling.

**RAD-HARD, ITAR FREE**  
**100 kRad and 60 MeV**

## FEATURES

### Electrical Performance

- Output ON/OFF Sequencing and Input Under Voltage Program
- Isolated Pulse ON/OFF Telecommand
- Telemetries: ON/OFF Status, Temperature, Output Voltage
- Automatic Shutdown of Positive Rails if the Negative Rail is Overloaded
- Low CE On Input & Output and High Input to Output CS Rejection
- WC EOL Output Voltage Accuracy:  $\pm 2\%$  Including Line and Load
- Transient Response:  $\pm 5\%$  for a 50% to 100% Load Step
- Low Quiescent Current When Commanded OFF

### Mechanical

PCB Outline Excl. Connectors      Mass  
MAHB: 85mm x 71mm x 19.5mm      < 95g

### Output CE:

All Outputs < 1.0mVrms (50Hz to 50MHz)

### CS Rejection Input to Outputs:

All Outputs > 85dB

### Output Configurations

Output 1: +2.5V to +8V	1.5A / 10W max
Output 2: +2.5V to +15V	1A / 5W max
Output 3: -1.5V to -15V	0.2A / 2.5W max
Output 4: +5V to +15V	1A / 5W max

## BENEFITS

### Standard Form-Factors, Tailored to Spec

- Fully Customizable to Match Satellite Platform and Payload Requirements
- Outputs Can Be Configured to Customer Specifications
- Four Individually Regulated Low Noise Outputs: 3 Positive & 1 Negative
- On-Board EMC Filters Ensures Compliance Without Additional Filtering
- Input to Output Power Efficiency of up to 71%
- Design Data Package & Product Control Documentation Available

### Design Expertise

Our team helps review and specify payload specific DC-DC converters to ensure maximum compatibility and minimum risk at equipment level. We design, develop, manufacture and test complete DC-DC solutions for effortless payload integration.

### Rapid Delivery for Tailored Designs:

- 6 Months for Engineering Models
- 9 Months for CDR Data Package
- 12 Months for Flight Units

*Typical Efficiency*

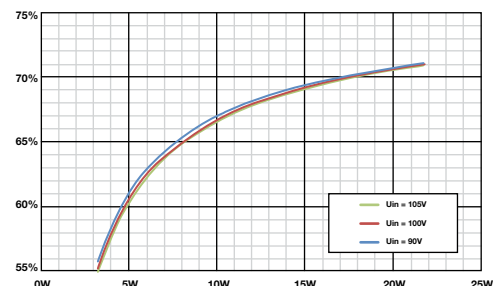

All 4 Outputs Loaded Equal Relative to Max Load

# MAHB Series

## GENERIC BLOCK SCHEMATIC

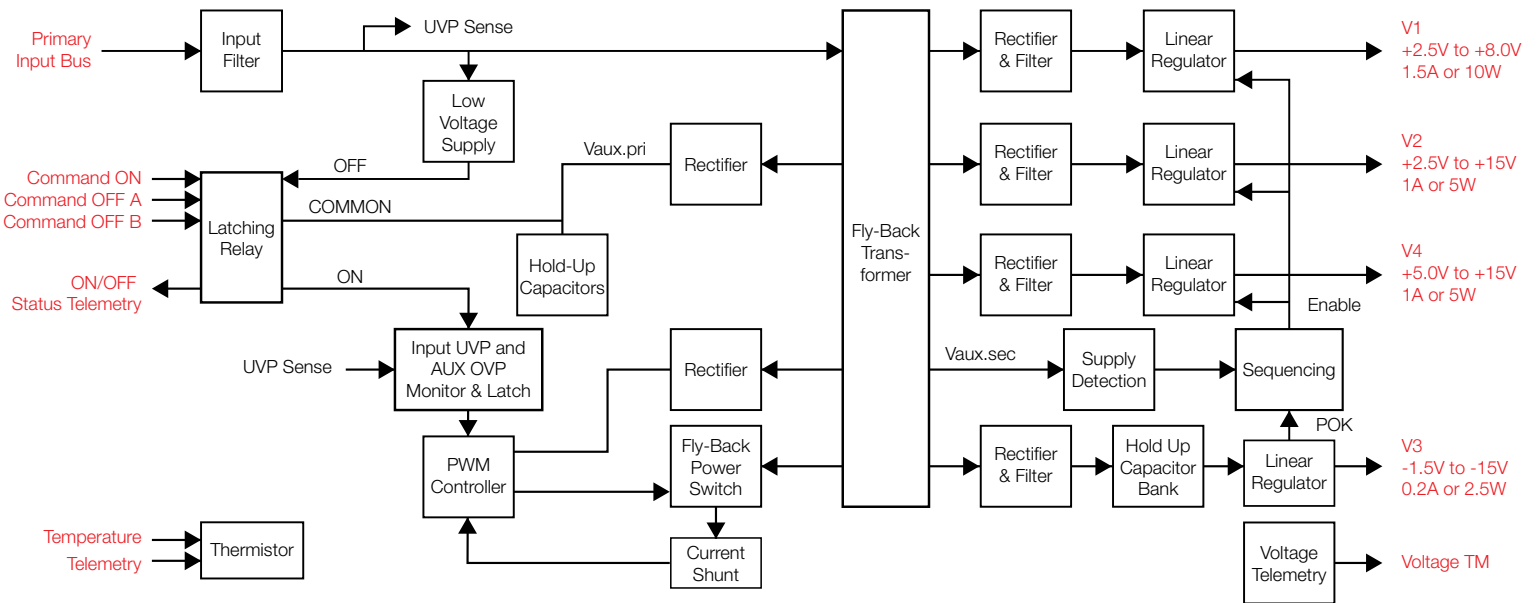

### Flight Qualified and Export Approved Configurations

Part Number	Input Voltage	V1	V2	V3	V4
12110	98V to 101V	+7.2 / 0.85A	+6.0V / 0.80A	-6.0V / 0.05A	+12.0V / 0.33A
12138	97V to 103V	+8.0V / 1.40A	+6.0V / 0.80A	-6.0V / 0.05A	+12.0V / 0.55A
12147	33V to 39V	+8.0V / 1.40A	+6.0V / 0.80A	-6.0V / 0.05A	+12.0V / 0.55A
12148	96V to 103V	+8.0V / 1.40A	+6.0V / 0.80A	-6.0V / 0.05A	+12.0V / 0.05A
12156	25V to 32.8V	+3.3V / 1.80A	+5.1V / 1.62A	-5.0V / -0.09A	Not Fitted
12157	31.5V to 52V	+3.3V / 1.80A	+5.1V / 1.62A	-5.0V / -0.09A	Not Fitted
12163	31.5V to 52V	+3.3V / 1.80A	+5.1V / 1.62A	-5.0V / -0.09A	Not Fitted
12169	33V to 39V	+6.0V / 1.50A	+8.0V / 1.65A	-6.0V / 0.10A	+12.0V / 0.55A
12181	98V to 101V	+7.2V / 1.40A	+6.0V / 1.40A	-5.0V / 0.05A	+12.0V / 0.55A
12186	98V to 101V	+5.2V / 0.93A	+10.1V / 1.20A	-5.4V / 0.07A	+15.0V / 0.03A
12198	22V to 35V	+6.0V / 0.80A	+8.0V / 0.60A	-6.0V / 0.05A	+12.0V / 0.10A

ECCN: 9A515.y.1

### About Micross

Micross is the most complete provider of advanced microelectronic services and component, die and wafer solutions. With the broadest authorized access to die & wafer suppliers, an extensive portfolio of hi-rel power, RF, optoelectronics, memory, data bus, logic, and SMD/5962 qualified products, and the most comprehensive advanced packaging, assembly, modification, upscreening, and test capabilities, Micross is uniquely positioned to provide unparalleled high-reliability solutions, from bare die, to fully packaged devices including hermetic ICs/MCMs, PEMS, ASICs, FPGAs, and PCBs, to complete program life-cycle sustainment. For more than 45 years, Micross has been a trusted source for the aerospace, defense, space, medical, energy, communications, and industrial markets.



### Need Information?

Quote Request: [micross.com/quotes](https://micross.com/quotes)  
 General Requests: [micross.com/info](https://micross.com/info)  
 Technical Support: [micross.com/tech-support](https://micross.com/tech-support)