

# KCB821

High Isolation SPDT  
0.02 – 4 GHz



## DESCRIPTION

KCB821 is a GaAs pHEMT Non-Reflective high performance, low loss switch in a 8 lead hermetic Surface-Mount Technology (SMT) package for Harsh Environments including Defense and Satellite application. This device can be ordered with the 100% screening requirements of MIL-PRF-38535 Class B and S, in addition to the required QCI.

## FEATURES

- ✓ **Low Loss: .8 dB @ 2 GHz Isolation: 45 dB @ 2 GHz.**
- ✓ **Non Reflective Match in off State (S22).**
- ✓ **NASA EEE-INST-002 compliant.**
- ✓ **Successfully Tested to 1M RAD TID.**
- ✓ **High Reliability Class B and S Screening Available.**
- ✓ **See Page 4 for MFR HI –REL Ordering Details.**

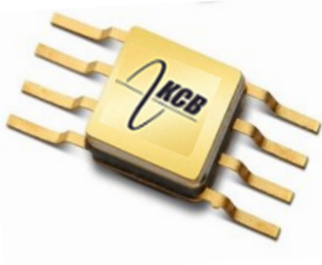

## ELECTRICAL CHARACTERISTICS (+25°C)

Parameter	Conditions	Min	Typical	Max	Units
Insertion Loss	0.02 – 2.0 GHz		0.7	1.0	dB
	2.0 – 3.0 GHz		0.8	1.2	dB
	3.0 – 4.0 GHz		0.9	1.4	dB
RF1/RF2 Return Loss (ON-State)	0.02 – 2.0 GHz	19	22		dB
	2.0 – 3.0 GHz	15	22		dB
	3.0 – 4.0 GHz	12	18		dB
RF1/RF2 Return Loss (OFF-State)	0.02 – 0.1 GHz	0	0		dB
	0.1 – 0.5 GHz	5	8		dB
	0.5 – 2.0 GHz	9	11		dB
	2.0 – 3.0 GHz	12	15		dB
	3.0 – 4.0 GHz	12	15		dB
Isolation	0.02 – 2.0 GHz	50	55		dB
	2.0 – 3.0 GHz	40	50		dB
	3.0 – 4.0 GHz	35	45		dB
Input 1 dB Compression (P1dB)	Vctl = 0V/+5V, 0.5- 2.0 GHz		+30		dBm
Third Order Output Intercept Point (IP3)	+8 dBm Input Tones, 1 MHz Spacing, Vctl = 0V/5V, 0.5- 2.0 GHz		+46		dBm
Switching Speed: Rise, Fall ON/OFF	10/90% or 90/10% RF 50% CTL to 90/10% RF		5		nS
			15		nS
Negative (Positive) Control					
Vctrl High	DC Voltage	-7.0 (+2.7)	-5.0 (+5.0)	-4.5 (+7.0)	V
Vctrl Low	DC Voltage	-0.25	0	+0.25	V
I ctrl	DC Current		50	200	uA

# TYPICAL PERFORMANCE (+25°C)

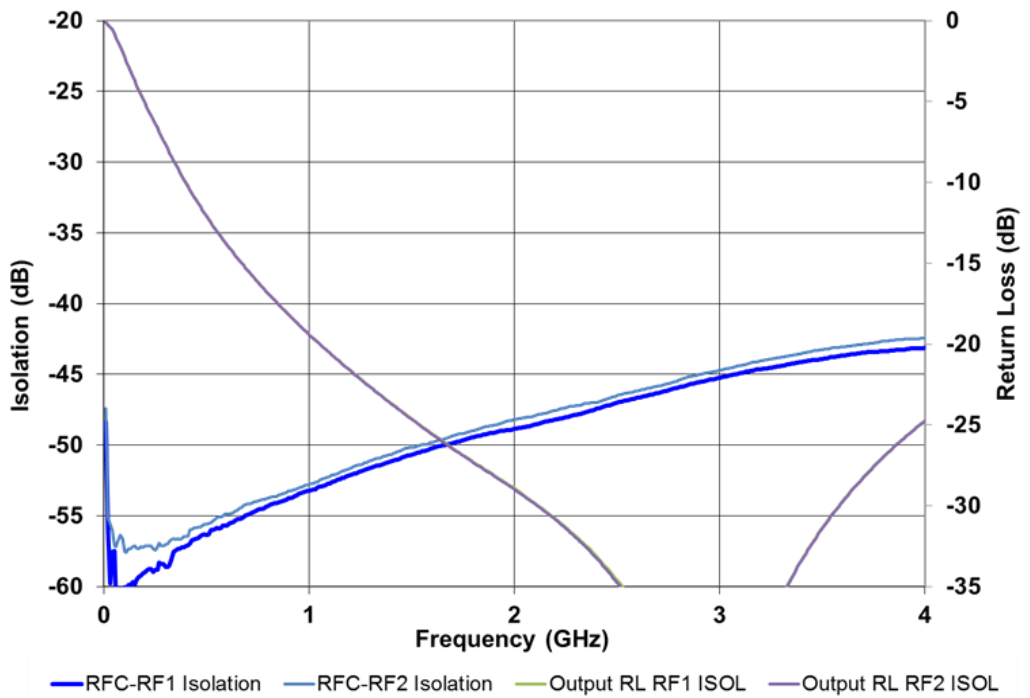
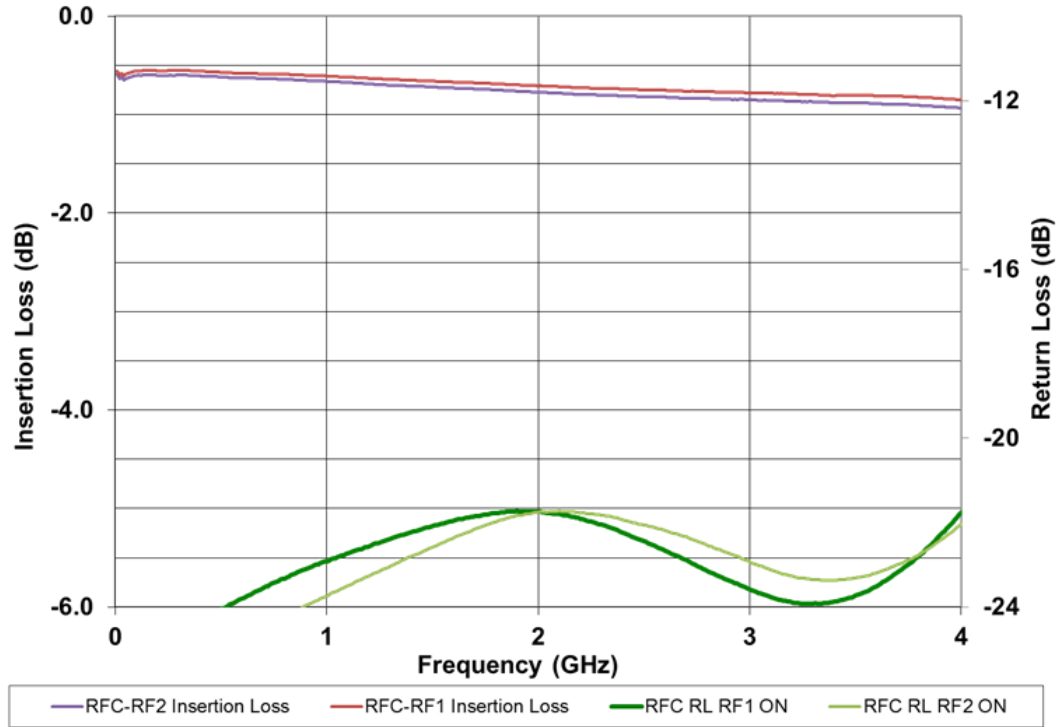

Note: Typical Insertion loss change .003db/degree C. .

## TRUTH TABLE/NEGATIVE CONTROL

Control Input		Signal Path State	
B	A	RFC to RF1	RFC to RF2
-5.0	0	ON	OFF
0	-5	OFF	ON

## TRUTH TABLE/POSITIVE CONTROL

Control Input		Signal Path State	
B	A	RFC to RF1	RFC to RF2
0	+5.0	ON	OFF
+5.0	0	OFF	ON

Note: External blocking capacitors are required on all RF ports. Capacitor should be selected to allow for low frequency operation.

## ABSOLUTE MAXIMUM RATINGS

Exceeding Max limits may cause damage

Characteristic	Min.	Max.	Units
Control Voltage (A+B)	-0.2	+9.0	Volts
RF Input Power		+30	dBm
Storage Temperature	-65	+150	°C
Operating Case Temp	-55	+125	°C
Junction Temperature		+150	°C
Operating Frequency	0.03	6.00	GHz

## SCHEMATIC

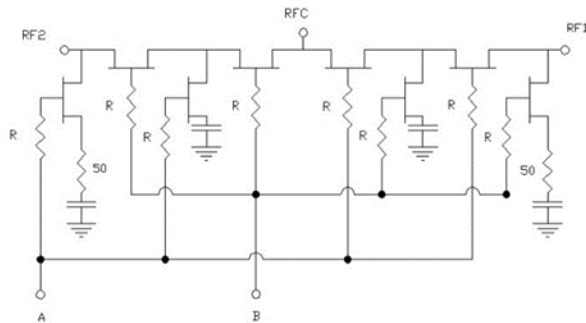

## PINOUT



XXX = Serial number will be added for Class B and S Part numbers

1	A
2	B
3	RFC
4	GND
5	RF1
6	GND
7	GND
8	RF2

## OUTLINE DRAWING

Dimensions are shown in inches.

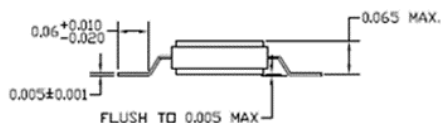
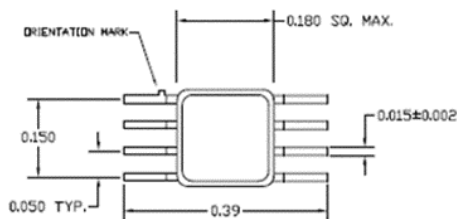

Electrostatic Sensitive Device. Proper ESD precaution should be used when handling device.

## MFR HI-REL SCREENING FLOW

Test Inspection	MIL – STD -883		Requirement	
	Method	Condition	Class B	Class S
Wafer Lot Acceptance /1	5007		N/A	Per Wafer Lot
Non-Destructive Bond Pull	2023		SPC	SPC
Internal Visual	2010	A= Class S, B = Class B	100%	100%
Temperature Cycle	1010	C	100%	100%
Acceleration	2001	E (Y1 only)	100%	100%
PIND	2020	A (5 Cycles)	N/A	100%
Serialization	Per Product Specification		100%	100%
Radiographic	2012	2 views	N/A	100%
Electrical Test	Small Signal Testing	+25°C	100%	100%
Burn In	1015	A	100%/160 Hours/125°C	100%/240 Hours/125 °C
Final Electrical	Small Signal Testing	+25°C	100%	100%
PDA Calculation	5004	25% Δ IL / 100% Δ Icc	5%	5%/3% functional
Group A Electrical /5	Per Product Specification	-55°C + 125°C	45/0	45/0
Leak Test	1014 A and C	1 x 10 <sup>-8</sup> Max	100%	100%
External Visual	2009		100%	100%

## NOTES

1. Product under configuration control per KCB QAP 015.
2. Customer will be notified of all class 1 changes for Class B and S part numbers.
3. Wafer Lot Acceptance will include 100% die visual, SEM analysis and Lot Traceability.
4. Electrical Test Data will be recorded for each serial number and included in Final Test Report for all Class S part numbers.
5. Group A Electrical testing will include the Small Signal and Ic at the Min/Max operating condition. The Dynamic test (P1dB, IP3, SS) will be tested at +25c only.

## ORDERING INFORMATION

	Unscreened	Class B	Class S
KCB Solutions Part Number	KCB821C	KCB821B	KCB821S

