

KCB815

High Isolation SPST
DC – 6GHz



DESCRIPTION

KCB815 is a GaAs pHEMT Non-Reflective high performance, low loss switch in a 7 lead Hermetic Surface-Mount Technology (SMT) package for Defense and Satellite application. This device can be supplied and tested to the screening requirements of MIL-PRF-38535 Class B and S, in addition to the required QCI.



FEATURES

- ✓ **Wideband frequency range: DC to 6 GHz**
- ✓ **Low Loss: 0.6 dB @ 2 GHz Isolation: 50 dB @ 2 GHz**
- ✓ **NASA EEE-INST-002 Compliant**
- ✓ **Successfully Tested to 1M RAD TID**
- ✓ **High Reliability Class B and S Screening Available**
- ✓ **See Page 4 for MFR Hi –Rel Ordering Details**

ELECTRICAL CHARACTERISTICS (+25°C)

Parameter	Conditions	Min	Typical	Max	Units
Insertion Loss	DC – 2.0 GHz		0.5	0.8	dB
	2.0 – 3.0 GHz		0.6	0.9	dB
	3.0 – 4.0 GHz		0.75	1.05	dB
	4.0 – 6.0 GHz		0.78	1.20	dB
RF1/RF2 Return Loss (ON-State)	DC – 2.0 GHz	20	25		dB
	2.0 – 3.0 GHz	20	25		dB
	3.0 – 4.0 GHz	18	22		dB
	4.0 – 6.0 GHz	15	18		dB
RF2 Return Loss (OFF-State)	DC – 2.0 GHz	18	20		dB
	2.0 – 3.0 GHz	18	20		dB
	3.0 – 4.0 GHz	18	20		dB
	4.0 – 6.0 GHz	15	20		dB
Isolation	DC – 2.0 GHz	50	57		dB
	2.0 – 3.0 GHz	45	55		dB
	3.0 – 4.0 GHz	38	45		dB
	4.0 – 6.0 GHz	27	35		dB
Input 1 dB Compression (P1dB)	Vctrl = 0V/-5V, 0.5- 2.0 GHz		+24		dBm
Third Order Output Intercept Point (IP3)	+13 dBm Input Tones, 1 MHz Spacing, Vctrl = 0V/5V, 0.5- 2.0 GHz		+46		dBm
Switching Speed: Rise, Fall ON/OFF	10/90% or 90/10% RF 50% CTL to 90/10% RF		5 15		nS nS
Vctrl High	DC Voltage	-4.5	-5.0	-7.0	V
Vctrl Low	DC Voltage	-0.2	0	+0.2	V
I ctrl	DC Current		50	200	uA

TYPICAL PERFORMANCE (+25°C)

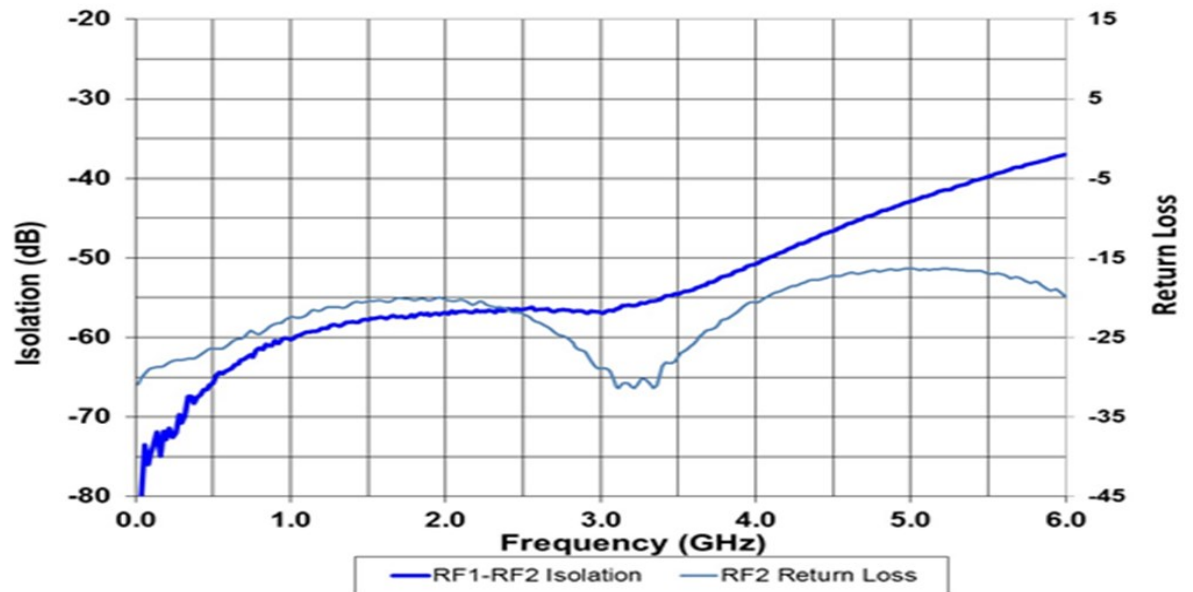
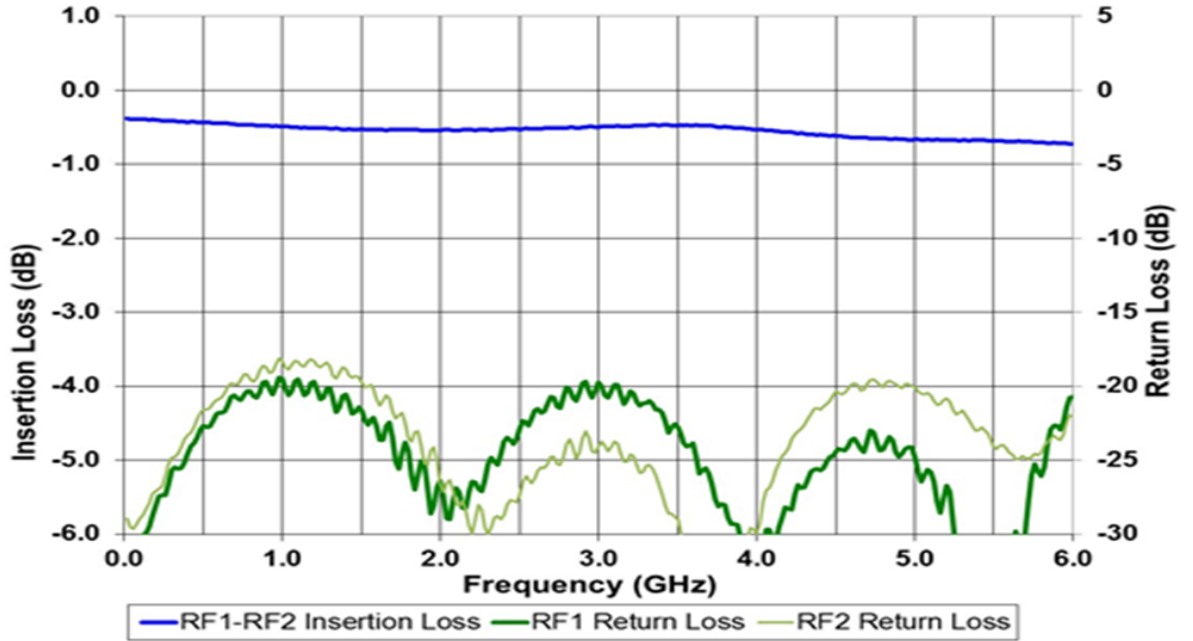

TRUTH TABLE/CONTROL VOLTAGES

Control Input		Signal Path State
A	B	RF1 to RF2
HIGH	LOW	ON
LOW	HIGH	OFF

State	Bias Conditions
Low	0 @ 20 μ A
High	-5V @ 100 μ A

SCHEMATIC

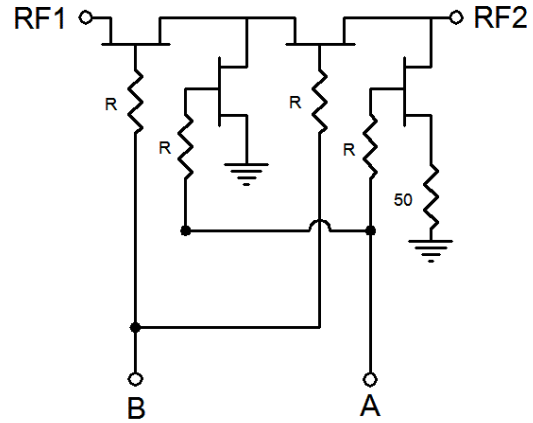

ABSOLUTE MAXIMUM RATINGS

Exceeding Max limits may cause damage

Characteristic	Min.	Max.	Units
Control Voltage	-7.5	+1.0	Volts
RF Input Power		+30	dBm
Storage Temperature	-65	+150	$^{\circ}$ C
Operating Case Temp	-55	+125	$^{\circ}$ C
Junction Temperature		+150	$^{\circ}$ C

PINOUT

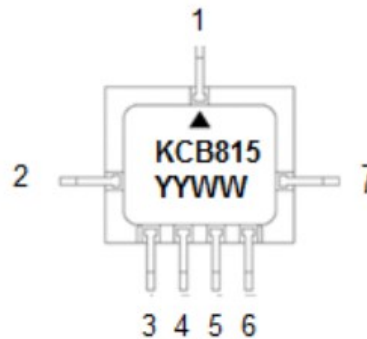

1	GND
2	RF1
3	GND
4	A
5	B
6	GND
7	RF2

XXX = Serial number will be added for Class B and S Part numbers

OUTLINE DRAWING

Dimensions are shown in inches.

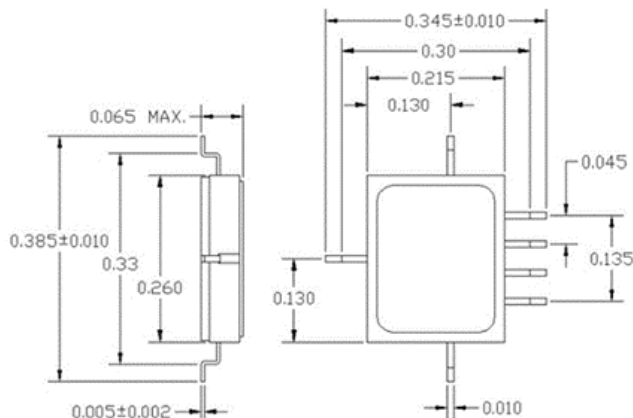

Electrostatic Sensitive Device. Proper ESD precaution should be used when handling device.



MFR HI-REL SCREENING FLOW

Test Inspection	MIL – STD -883		Requirement	
	Method	Condition	Class B	Class S
Wafer Lot Acceptance /1	5007		N/A	Per Wafer Lot
Non-Destructive Bond Pull	2023		SPC	SPC
Internal Visual	2010	A= Class S, B = Class B	100%	100%
Temperature Cycle	1010	C	100%	100%
Acceleration	2001	E (Y1 only)	100%	100%
PIND	2020	A (5 Cycles)	N/A	100%
Serialization	Per Product Specification		100%	100%
Radiographic	2012	2 views	N/A	100%
Electrical Test	Small Signal Testing	+25°C	100%	100%
Burn In	1015	A	100%/160 Hours/125°C	100%/240 Hours/125 °C
Final Electrical	Small Signal Testing	+25°C	100%	100%
PDA Calculation	5004	25% Δ IL / 100% Δ Icc	5%	5%/3% functional
Group A Electrical /5	Per Product Specification	-55°C + 125°C	45/0	45/0
Leak Test	1014 A and C	1 x 10 -8 Max	100%	100%
External Visual	2009		100%	100%

NOTES

1. Product under configuration control per KCB QAP 015.
2. Customer will be notified of all class 1 changes for Class B and S part numbers.
3. Wafer Lot Acceptance will include 100% die visual, SEM analysis, and Lot Traceability.
4. Electrical Test Data will be recorded for each serial number and included in Final Test Report for all Class S part numbers.
5. Group A Electrical testing will include the Small Signal and Ic at the Min/Max operating condition. The Dynamic test (P1dB, IP3, NF) will be tested at +25c only.

ORDERING INFORMATION

	Unscreened	Class B	Class S
KCB Solutions Part Number	KCB815C	KCB815B	KCB815S

